

# Exlar Tritex II Product Catalog

Intelligent Drive Motor Actuators

**CURTISS -  
WRIGHT**

**EXLAR®**

Specifications

Drawings

Ordering

And More...

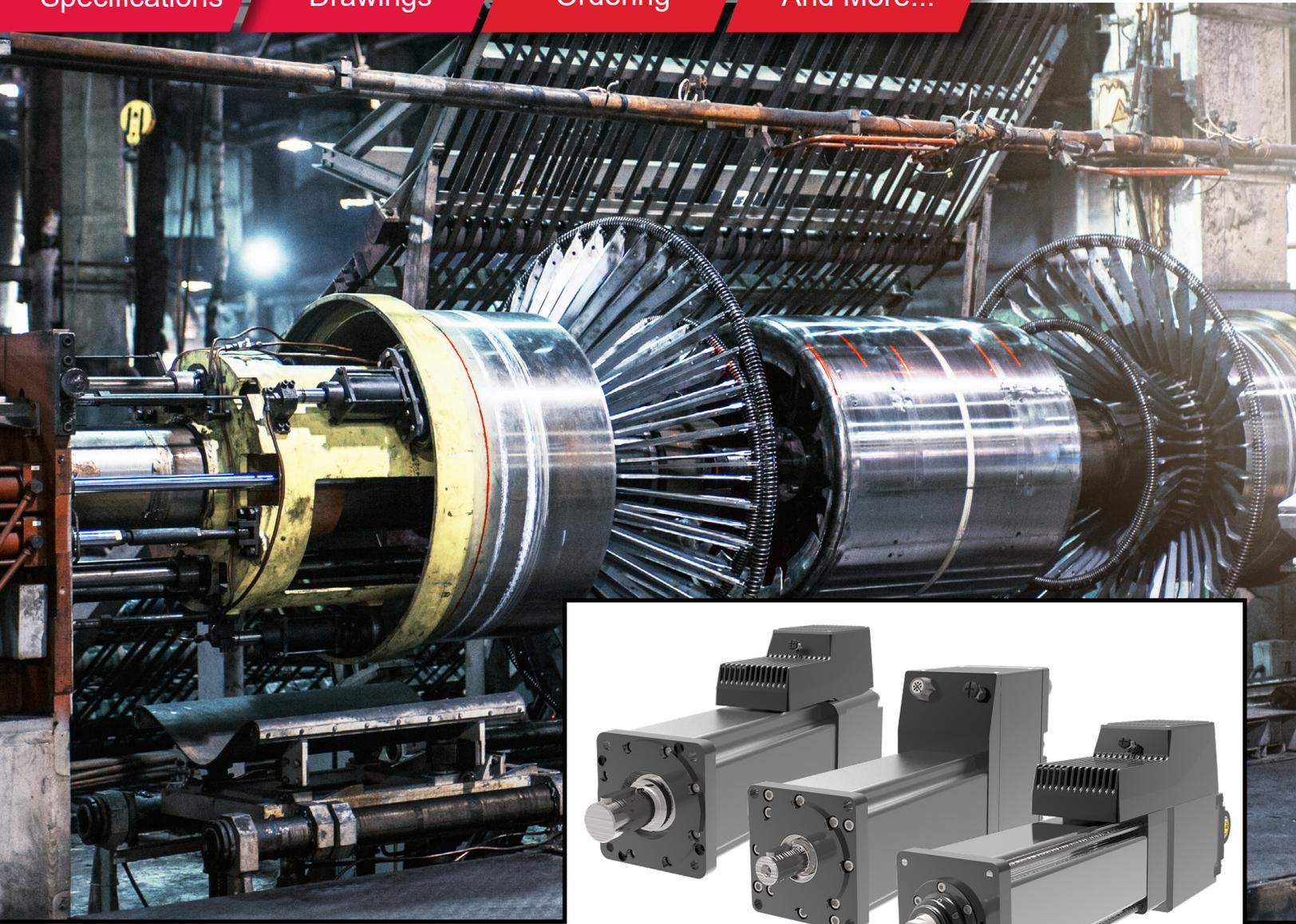

## Tritex II Intelligent Drive Motor Actuators

**Power | Precision | Proven**

May 2025

## Contents

Tritex® Series.....	4
Linear Applications.....	5
Rotary Applications .....	5
Tritex II Models.....	5
Tritex II Series Operation .....	6
Tritex II AC .....	11
Communications & I/O.....	12
Product Features .....	13
Industries and Applications.....	14
Mechanical Specifications .....	15
Estimated Service Life.....	16
Speed vs. Force Curves .....	16
Options .....	19
Dimensions.....	20
Mechanical Specifications .....	24
Speed vs. Torque Curves .....	27
Dimensions.....	28
Ordering Information.....	31
Cable and Accessories .....	33
Tritex II DC	
Linear & Rotary Actuators.....	34
Communications & I/O.....	35
Product Features .....	36
Industries and Applications.....	37
Options .....	37
Mechanical Specifications .....	38
Speed vs. Torque Curves .....	41
Dimensions.....	42
Ordering Information.....	45
Cables and Accessories .....	46
Warranty and Limitations of Liability .....	48

# TRITEX II® SERIES

FULLY INTEGRATED SERVO DRIVE/MOTOR/ACTUATOR

Linear or Rotary configurations

AC or DC powered models

Multiple networking options

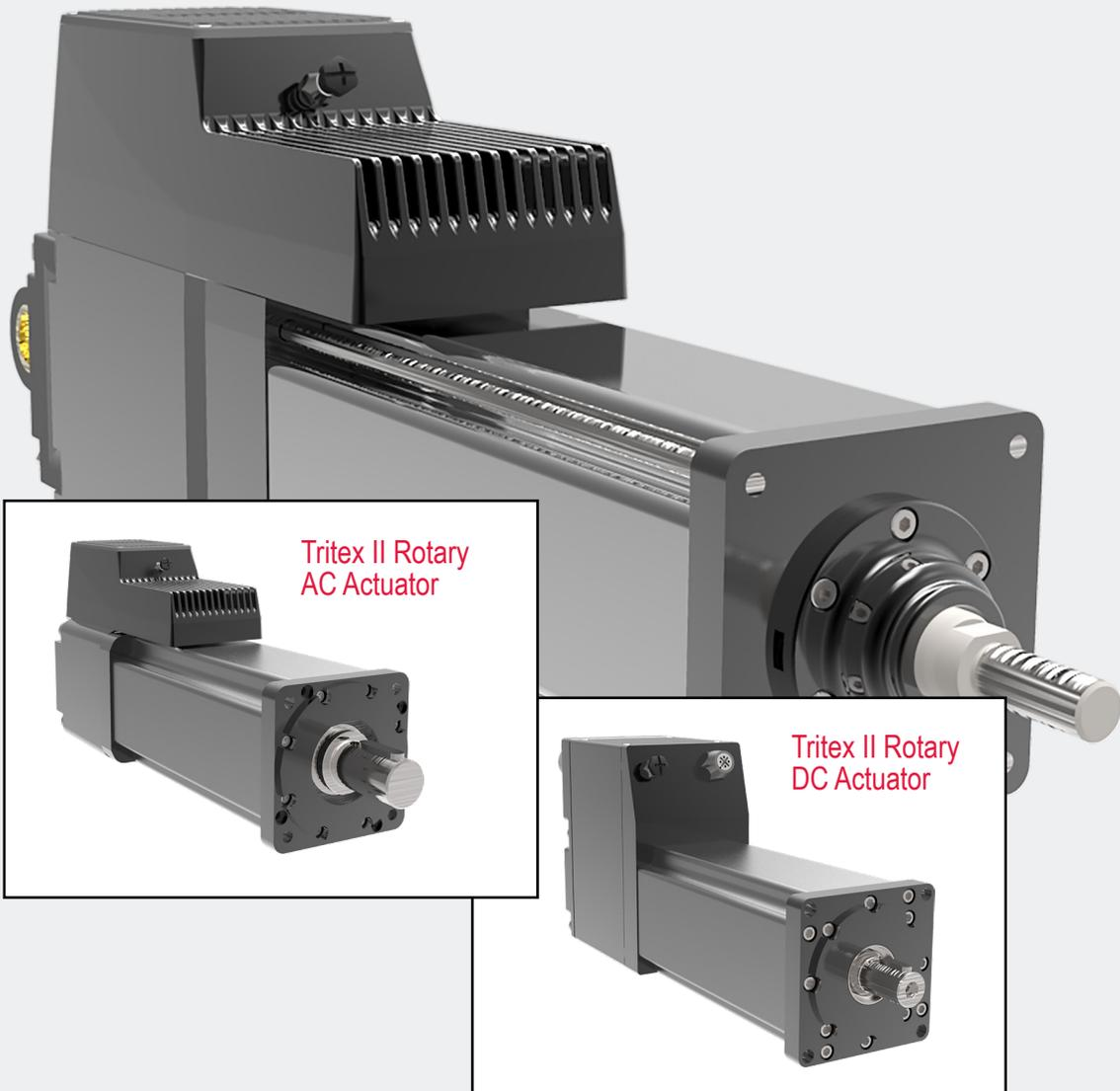

## Tritex® Series

### Fully Integrated Drive/Motor/Actuator

By combining the latest electronic power technology with advanced thermal management modeling technology, Exlar® has set a new benchmark for electric actuator performance versus size. Tritex II actuators now integrate an AC or DC powered servo drive, digital position controller, brushless motor and linear or rotary actuator in one elegant, compact, sealed package. Now you can distribute motion control and resolve your application challenges with one integrated device. Simply connect power, I/O, communications and go!

### Dramatically Reduce Space Requirements

Tritex II actuators are the highest power density, smallest footprint servo drive devices on the market. Finally, you can incorporate a fully electronic solution in the space of your existing hydraulic or pneumatic cylinder. You can also eliminate troublesome ball screw actuators or bulky servo gear reducers. And the space previously consumed by panel mount servo drives and motion controllers is no longer needed. Tritex II actuators may also reduce the size of your machine design while significantly improving reliability.

### Reduce Costs

Now you can eliminate the labor costs for mounting and wiring panels because the Tritex II houses the servo drive, digital positioner, and actuator in one convenient package. Cable costs are also significantly reduced by eliminating the need for expensive, high-maintenance specialty servo cables. All that is required is an economical standard AC or DC power cord, and standard communication cable for digital and analog I/O.

These actuators also eliminate the issues associated with power signals and feedback signals traveling long distances from servo drive to servo motor. With the Tritex II, the servo drive and motor are always integrated in the same housing.

### Flexible Communications

Multiple feedback types, including absolute feedback, allow you to select the system that is best-suited for your application. Digital and analog I/O, plus popular communication networks, such as Modbus TCP, Ethernet/IP, and PROFINET IO, allow the Tritex II to become an integral part of your control architecture or machine control processes.

### Improves Power, Performance, and Reliability

Tritex II actuators give you unrivaled power, performance, and reliability. No longer are you limited to trivial amounts of force or speeds so slow that many motion applications are not possible.

#### Tritex II AC Actuator

- Continuous force to 3225 lbf (14kN)
- Peak force to 5400 lbf (24kN)
- Speed to 33 in/sec (800 mm/sec)
- 1.5 kW servo amplifier
- Temperature operation range -40°C to +65°C
- AC power 100V – 240V, +/-10%

#### Tritex II DC Actuator

- Continuous force to 872 lbf (4kN)
- Peak force to 1190 lbf (5kN)
- Speed to 33 in/sec (800 mm/sec)
- 750W servo amplifier
- Temperature operation range -40°C to +65°C
- DC power 12-48 VDC nominal

Tritex II System

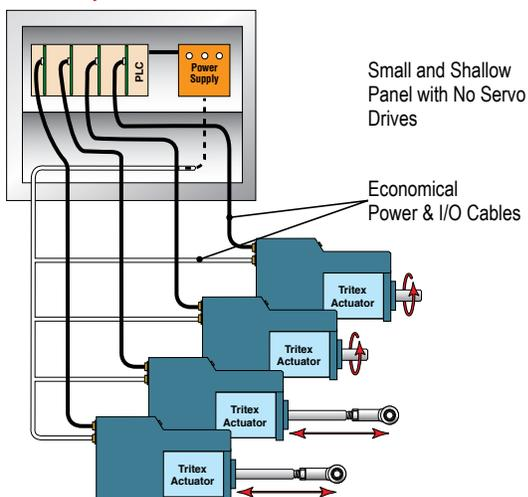

Alternative Systems

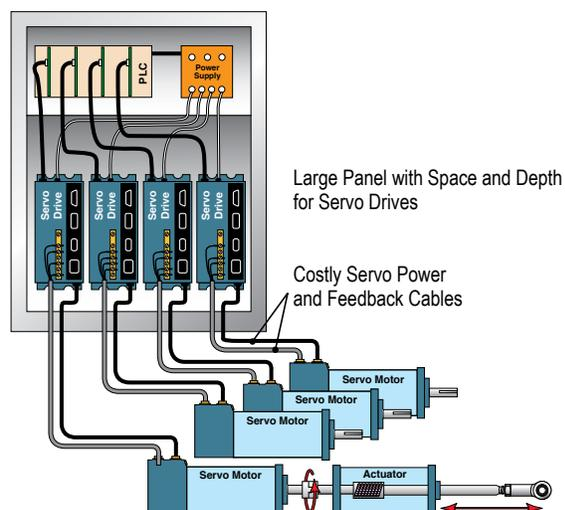

## Linear Applications

Tritex II linear actuators employ a superior inverted roller screw mechanism for converting rotary motion to highly robust and long-life linear motion. These characteristics enable the Tritex actuator to solve applications that previously required pneumatic or hydraulic cylinders. No additional mechanisms (such as acme or ball screws) are necessary to convert the actuator's rotary power into linear motion in order to move the load.

Ideal for mobile and remote applications using DC power sources, the Tritex II DC actuators have the power needed to perform. The simple to configure, yet robust interface software allows either the AC or DC Tritex II actuators to perform nearly any motion control application. The Tritex II linear actuator can be programmed to follow an analog command signal, making it ideal for controlling valves and dampers in process control applications or adjustment mechanisms on mobile equipment.

### Longer Stroke Lengths

If your application requires a stroke length greater than the 18 inches available with Tritex II linear units, consider mounting a rotary Tritex II actuator to an Exlar universal actuator. This combination extends stroke length up to 40 inches. Please contact Exlar for more details.

## Tritex II Models

### Tritex II AC Models

- T2X high mechanical capacity actuator, 90 and 115 mm
- R2M rotary motor, 75, 90, and 115 mm
- R2G rotary gearmotor, 75, 90, and 115 mm

### Tritex II DC Models

- RDM rotary motor, 60, 75, and 90 mm
- RDG rotary gearmotor, 60, 75, and 90 mm

### Feedback Types (All Models)

- Analog Hall w/1000 count resolution
- Incremental encoder with 8192 count resolution
- Absolute Feedback (analog hall with multi-turn, battery backup)

### Communications & I/O

The I/O count and type varies with each actuator model and option selected.

### Standard Communications (All Models):

- 1 RS485 port, Modbus RTU, opto-isolated for programming, controlling and monitoring

## Rotary Applications

Tritex II rotary motors and gearmotors provide high response and precise control of a rotatable shaft, similar to that found in any electric motor. The difference is that with Tritex II you can program (via your PC) the rotational speed and position of the output shaft in response to external commands. For example, the motor can be commanded to rotate at a controlled velocity and to precisely stop at a preprogrammed position. You can also program the unit to run at a preset velocity until a switch input is received or a preprogrammed torque level is produced against a load. Alternatively, the rotary Tritex II actuators can be set up to follow an analog signal—either voltage or current—representing your choice of torque, velocity, or position.

Signals for initiating the preprogrammed velocity and position commands come from optically isolated inputs or directly via network communications. Likewise, isolated output commands of the status and events enable precise coordination with your system controls or machine operator.

### Optional Internal Gear Reducer

If your application requires greater torque and less speed than the base unit provides, the Tritex II is available with an integral servo grade planetary gear reducer. Gear ratios of 4:1 to 100:1 allow the power of Tritex II to be applied over a broad range of torque requirements.



## Tritex II Series Operation

The Tritex II Series actuators can operate in one of five different motion-producing modes. These modes solve an endless variety of applications in industrial automation, medical equipment, fastening and joining, blow molding, injection molding, testing, food processing, and more.

Programmed functions are stored in the Tritex II non-volatile memory. A standard RS485 serial interface allows control, programming, and monitoring of all aspects of the motor or actuator as it performs your application. Optional communications protocols are available.

### Tritex Option Boards

- Option boards offer adding functionality to the base Tritex II actuators
  - Terminal board for customer I/O
  - Isolated 4-20mA analog input and output
- Communication buses
  - EtherNet/IP
  - Modbus TCP
  - PROFINET IO

### Connectivity

- Internal terminals accessible through removable cover (select models)
- Threaded ports for cable glands (select models)
- Optional connectors
  - M23 Power - M23/M16 I/O
- M8 connector for RS485
- M12 connector for EtherNet options
- Embedded leads (select models)

## Operating Modes

1. *Move to a position (or switch)*  
The Tritex II Series actuators allow you to execute up to 16 programmed positions or distances. You may also use a limit switch or other input device as the end condition of a move. This combination of index flexibility provides a simple solution for point-to-point indexing.
2. *Move to a preset force or torque*  
The Tritex II Series allows you to terminate your move upon the achievement of a programmed torque or force. This is an ideal mode for pressing and clamping applications.
3. *Position proportional to an analog signal*  
Ideal for process control solutions, the Tritex II Series provides the functionality to position a control valve by following an analog input signal. Therefore, it delivers precise valve control — which cannot be achieved by other electric, hydraulic, or pneumatic actuators.
4. *Velocity proportional to an analog signal*  
Tritex II actuators offer you the capability to control velocity with an analog signal. This is particularly useful with Tritex II rotary motors which offer precise control of the speed of any process or operation.
5. *Force/torque proportional to analog signal*  
Perfect for pressing and torquing applications, you can control torque with an analog input while in torque mode.

### Selectable Input Functions

- Enable • Execute Move (0-15) • Dedicated Position • Jog+
- Jog- • Jog Fast • Home • Extend Switch • Retract Switch
- Home Switch • Teach Enable • Teach Move (1-16)
- Select Move • Stop • Hold • Reset Faults
- Alternate Mode (allows you to switch between 2 operating modes)

### Selectable Output Functions

- Enabled • Homed • Ready (Enabled and Homed)
- Fault • Warning • Fault or Warning Active
- Move (0-15) in Progress • Homing • Jogging
- Jogging+ • Jogging- • Motion • In Position
- At Home Position • At Move (0-15) • Position
- Stopped • Holding • In Current Limit • In Current Fold Back
- Above Rated Current • Home

## Expert User Interface

Expert, the Tritex II user interface software, provides you with a simple way to select all aspects of configuration and control required to set up and operate a Tritex II actuator. Easy-to-use tabbed pages provide access to input all of the parameters necessary to successfully configure your motion application. 'Application' files give you a convenient way to store and redistribute configurations amongst multiple computers, and 'Drive' files allow the same configuration to be distributed to multiple Tritex II actuators. Motion setup, homing, teach mode, tuning parameters, jogging, I/O configurations, and local control are all accomplished with ease using Expert software.

## Protocol Options

The standard communication protocol for Tritex is an RS485 connection using Modbus RTU. The Modbus protocol provides a simple and robust method to connect industrial electronic devices on the same network. The Expert software acts as a Modbus Master and the Tritex II acts as the Slave device, only responding to requests commanded through the software. The Expert software allows full access to commissioning, configuring, monitoring, and controlling the Tritex II.

In addition the following protocol options are available by selecting the communication option boards. Exlar requires initial commissioning of a Tritex II actuator to be performed with the Modbus protocol.

### Modbus TCP

Modbus TCP couples Modbus communication structure from Modbus RTU with EtherNet connectivity. The Modbus TCP option is fully supported by the Expert software and offers seamless

commissioning, configuring, monitoring and controlling the Tritex II. Communication protocol DSP 301 is supported as well as DSP 402 supporting Profile Torque, Profile Velocity, Profile Position and Homing. Setup on the system is most easily achieved with the Expert software using the RS485 port. A Modbus mapping table allows you to map all of the parameters you wish to read and modify into a register bank of up to 100 registers. This allows a PLC program to perform a single read operation and a single write operation to all the parameters.

### EtherNet/IP

EtherNet/IP allows you to change, monitor, and control the Tritex II through implicit or explicit messaging initiated from your Rockwell PLC. Tritex parameters are set up through the Expert software using a Tritex II parameter to EtherNet/IP parameter mapping table. Up to 100 input, and 100 output 16 bit registers can be mapped to Tritex II parameters.

### PROFINET IO

PROFINET IO allows you to change, monitor and control the Tritex II from your Siemens PLC. Tritex parameters are set up through the Expert software using a Tritex II parameter to PROFINET IO parameter mapping table. Up to 100 input and 100 output, 16 bit registers can be mapped to Tritex II parameters.

## Modbus Mapping Screen

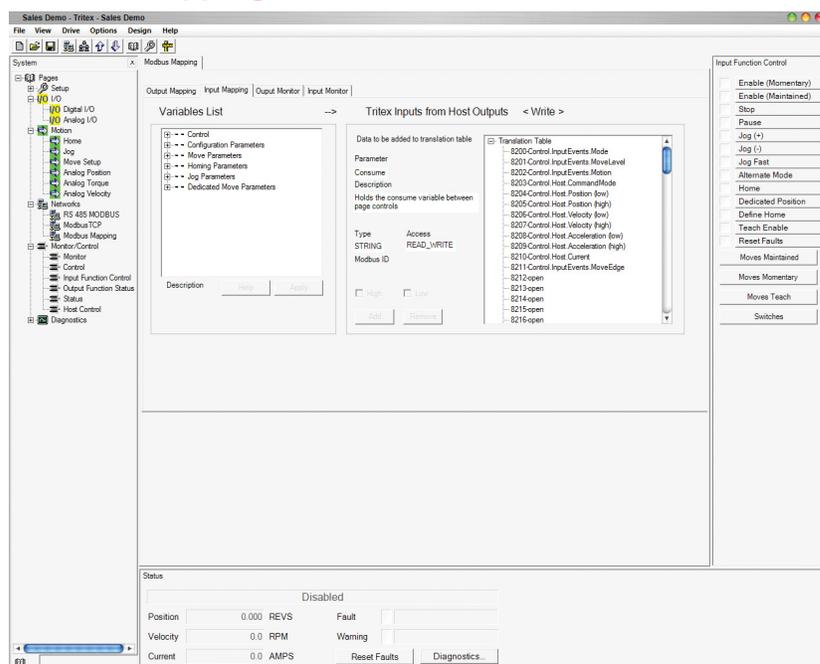

## Motion Setup

Exlar configuration provides several templates for various applications. These can serve as your configuration, or as a starting point for your configuration. You can also begin by selecting configuration details specific to your application. At the click of a button, you can configure a move to position, move to switch, or move to force motion. Tritex II products offer absolute and incremental motion, as well as moves ending on a condition, such as a specific force or torque.

## Control Page

The Expert control page gives you the ability to initiate all motion functions from one simple screen. This screen provides you with very easy system start-up and testing, without all the inconvenience of machine wiring.

The control page offers the capability to enable and disable the drive, and perform fast and slow jogs. This gives you the ability to verify motion, before needing any I/O wiring.

## Monitoring and Diagnostics

All input functions can be monitored and activated from the Expert monitor page, and all output functions can be monitored. Critical fault and status data is available as a separate page, or as a fixed window on the bottom of each page of the software.

## Configuring I/O

A drop down menu allows all I/O to be set up in a matter of minutes. Inputs can be configured to be maintained or momentary, depending on the application requirements. Input and output logic can be inverted with a single click.

## Scope

The Expert Software includes a four-channel digital oscilloscope feature.

You can select up to four Tritex drive parameters to be monitored simultaneously.

For high speed requirements, the data can be captured in the drive's memory at an adjustable rate, down to 100 micro seconds, and then uploaded for plotting. The plots can be saved or printed, and the captured data can be saved as a comma separated file for further analysis with Excel.

## Homing

You can home to an input, by using a proximity or limit switch, or home to a specific force or torque.

Homing to a force or torque is ideal for setting up applications that require motion referenced to a hard stop, like the closed position of a valve, or the final position of a press.

## Teach Mode

In this mode, you can jog the actuator to the desired position, and activate an input. Alternatively, you can click a button in the Expert software and the current position of the actuator becomes the defined distance or absolute position associated with a particular move command.

## EtherNet IP Mapping Screen

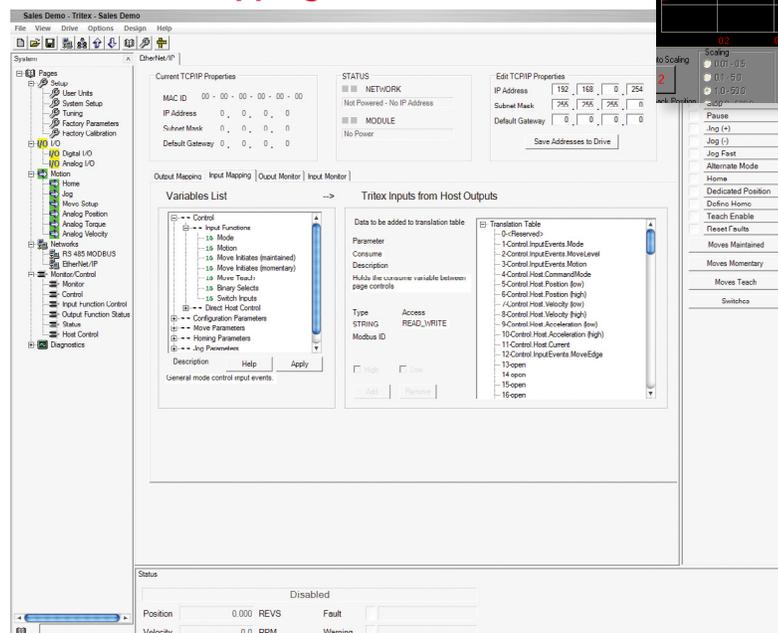

## Scope

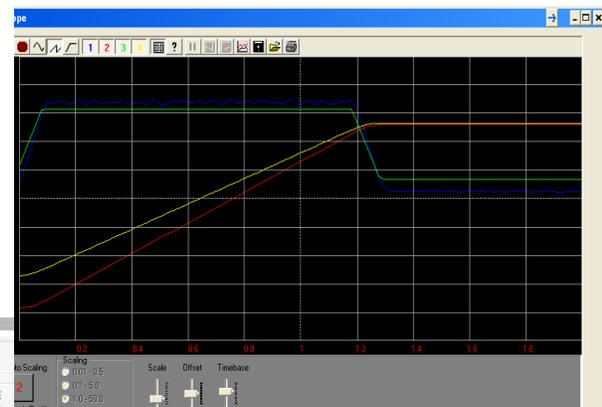

## Process Control Functionality

Precise valve and damper control are perfect applications for Tritex II actuators. They outperform other electric, hydraulic and pneumatic actuators by providing small hysteresis and dead band, quick response to small signal changes, and stable dynamic responses. Fully programmable to follow an analog or digital signal representing either position or force, the Tritex II linear actuator is well suited for control valve applications with thrust requirements up to 3225 lbf or rotary torque applications up to 95 lbf-in continuous.

The Tritex II Rotary actuators are also ideal for directly operating quarter-turn valves. Gear ratios of 4:1 to 100:1 allow the power of Tritex II to be applied to a broad range of applications, providing high turndown without loss of accuracy.

Additionally, Tritex II actuators can be mounted on any valve from any manufacturer giving you maximum flexibility.

## Valve Software

The valve software is simple to use and features a teach mode for foolproof stroke configuration. A programmable valve cut off position enables a firm valve seat on either new valves or retrofitted valves. Several diagnostics and auxiliary I/O options are also available.

## Class I, Division 2 Rating

Exlar Tritex II actuators are available for applications requiring CSA Class I Division 2 certification. Ordering a standard I/O interconnect with or without 4-20 mA Analog I/O, and the N option for the NPT port will provide you with a Class I Division 2 rated product.

## Benefits for Process Control Applications

### Extreme Accuracy

The Exlar actuators stroke the valve based on position, not air or oil pressure. Accuracy and repeatability are better than 0.1%.

### 100% Duty Cycle

A roller screw provides a unique way of converting rotary motor motion to a linear force, and offers full modulation capability. Life is measured in hundreds of million strokes vs. thousands like typical electric actuators.

### Built in Positioner

Tritex II actuators include a built in positioner with a 4-20 mA or digital signal to tell you the exact stroke position. An analog output is also available.

### Flexibility

These actuators include digital I/O and analog control. This provides the user with options for additional control such as emergency stop, +/- jog, or various diagnostic conditions.

### Low Power Consumption

The Tritex II actuator only uses the current needed for a given force. This extreme efficiency makes it suitable for use with solar panels and batteries.

### Fast Response and Stroke Speeds

Most other electric actuators are known for being slow—a major disadvantage. Tritex II response rate is measured in milliseconds. Stroke speeds can be up to 33 in/sec.

The screenshot displays the Tritex II valve control software interface, which includes several functional areas:

- Actuator Direction:** A dropdown menu set to 'Extend to Close'.
- Close Valve / Open Valve:** Two panels for setting parameters when the valve is closed or open, including current (mA) and velocity (REVS) values.
- Valve Stroke:** A text box explaining that the stroke length is the difference between the Open and Closed Valve Positions, with a note that the Open Valve Position must be greater than the Closed Valve Position.
- Velocity / Acceleration:** Fields for Velocity Limit (100.0 RPM) and Acceleration Limit (3000 RPM/S).
- Manual Teach Controls:** Buttons for 'Jog to Closed Position', 'Teach Closed Position', 'Jog to Open Position', and 'Teach Open Position', along with a 'Seating Current' indicator.
- Valve Seating:** A section for setting 'Travel Cut-off Position' (0.00% for Closed, 100.00% for Open) and 'Seating Limits' (Seating Velocity, Peak Seating Current, and Holdback Seating Current).
- System Status:** A top bar showing 'Power-Up 69 Time 19.08 HRS'.
- Last Fault/Warning Table:**

Fault Name	Count	Power-Up	Time [HRS]
Peak Current	0	0	0.00
Continuous Current	6	43	0.48
Position Tracking	34	60	10.82
Low Bus Voltage	0	0	0.00
High Bus Voltage	1	14	0.00
Following Error	1	65	11.83
Board Temperature	0	0	0.00
Communications	10	67	19.00
Actuator Temperature	0	0	0.00
Abx Hall Battery	0	0	0.00
Loss of Signal	0	0	0.00
Hardware Current Trip	0	0	0.00
- Recent Fault History Table:**

Power-Up	Time [HRS]	Fault Name
1	67	19.00 Communications
2	66	17.23 Communications
3	66	15.58 Communications
4	66	13.92 Communications
5	65	12.45 Communications
6	65	11.83 Following Error
7	65	11.68 Communications
8	60	10.82 Position Tracking
9	59	10.82 Position Tracking
10	58	10.82 Position Tracking
- Maximum Stress Values:**

Current	20.5 AMPS
Voltage	114.72 VOLTS
Board Temp	52.5 DEG(C)
Actuator Temp	0.0 DEG(C)
- Clear Plan Time / Current Power-On Stress Values:**

Current	0.0
Voltage	23.91

## Hydraulic Replacement

Tritex actuators have the same capabilities as a hydraulic equivalent, but without the cost or maintenance issues. High force, fast speeds and precise movements make it a superior substitute for hydraulic applications.

## Absolute Feedback

The absolute feedback option gives the actuator memory after teaching the valve limits. So upon power loss, the battery backup will maintain the valve limits.

## Diagnostics

All inputs and outputs can be monitored including position, temperature, current, and many more. An oscilloscope feature allows you to select up to four parameters to be monitored simultaneously. The data can be captured in the drive's memory at an adjustable rate, down to 100 micro sec, and then uploaded for plotting.

## Tritex II Agency Approval

If your application requires CSA Class I, Division 2 Certification, please order the "N" connection option for the NPT port. This, in combination with one of the following I/O option boards, will provide Class I, Division 2 Certification:

- SIO • EIN • TCN • IA4 • PIN

Shown below are additional agency approvals applied to Tritex II Actuators.

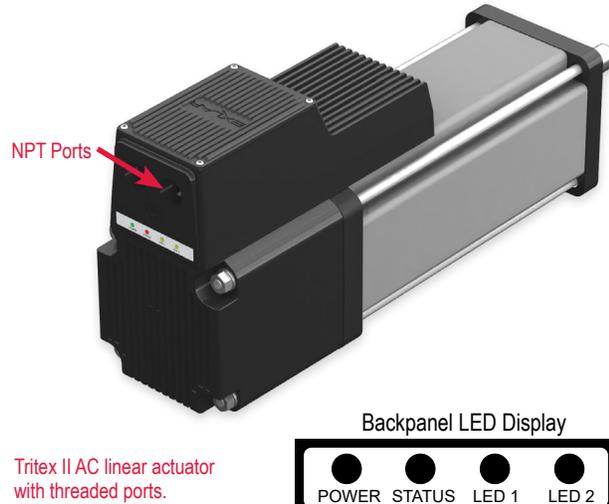

Tritex II DC Standards/Agency Approvals	
Agency/Standard	Tritex II Models/Options
CE, EMC EN61800-3	All models
CSA 139	All models, when supply voltage is 24 VDC or less
CSA Class I, Div 2, Groups A, B, C, D	90 mm frames require NPT connection option (N/A with 60 mm frame)
IP Rating	RDM/G = IP65
Vibration Rating	IEC 60068-2-64 random vibration standard, 5g rms, 50 to 500 Hz.
ODVA	EIP
PROFINET	PIO

Tritex II AC Standards/Agency Approvals	
Agency/Standard	Tritex II Models/Options
CE, EMC EN61800-3, Safety EN 61800-5-1	All options
CSA 139	All options
CSA Class I, Div 2, Groups A, B, C, D	Requires NPT connection option. Option Board EIN, PIN, TCN, and SIO, or IA4
UL 508 C, Type 4 Enclosure T2M090/R2M090 T2M115/R2M115	Requires NPT connection option. Option Board EIN, PIN, TCN, and SIO, or IA4
IP Rating	T2X = IP65S R2M/G & RDM/G = IP65S, R2M/G075, RDM/G075 = IP65S
Vibration Rating	IEC 61800-5-1 safety standard for drives. 1g peak, up to 150 Hz for <2 hrs. IEC 60068-2-64 random vibration standard, 2.5 g rms, 5 to 500 Hz.
ODVA	EIP

Up-to-date certifications for all products shown on [www.exlar.com](http://www.exlar.com).

## Tritex II AC

### No Compromising on Power, Performance or Reliability

With forces to approximately 3,225 lbf (14 kN) continuous and 5,400 lbf peak (24 kN), and speeds to 33 in/sec (800 mm/sec), the AC Tritex II linear actuators also offer a benefit that no other integrated product offers: POWER! No longer are you limited to trivial amounts of force, or speeds so slow that many motion applications are not possible. And the Tritex II with AC power electronics operates with maximum reliability over a broad range of ambient temperatures: -40°C to +65°C. The AC powered Tritex II actuators contain a 1.5 kW servo amplifier and a very capable motion controller. With standard features such as analog following for position, compound moves, move chaining, and individual force/torque control for each move, the Tritex II Series is the ideal solution for most motion applications.

#### Tritex II Models

- T2X high mechanical capacity actuator-90 and 115 mm
- R2M rotary motor
- R2G rotary gearmotor

#### Power Requirements

- AC Power 100V - 240V, +/- 10%, single phase
- Built-in AC line filter
- Connections for external braking resistor

#### Feedback Types

- Analog Hall with 1000 count/motor rev resolution
- Incremental encoder with 8192 count resolution
- Absolute Feedback (analog hall with multi-turn, battery backup)

#### Connectivity

- Internal terminals accessible through removable cover
- Threaded ports for cable glands
- Optional connectors:
  - M23 Power
  - M16 I/O (M23 on 75 mm)
- M8 connector for RS485
- M12 connector for Ethernet options
- Custom connection options

Tritex II AC Linear Actuator (90 mm)



Technical Characteristics	
Frame Sizes in (mm)	3.5 (90), 4.5 (115)
Screw Leads	0.1 (2), 0.2 (5), 0.5 (13), 0.75 (19)
Standard Stroke Lengths in (mm)	3 (76), 4 (102), 6 (152), 10 (254), 12 (305), 14 (356), 18 (457)
Force Range	up to 3225 lbf (14 kN)
Maximum Speed	up to 33.3 in/s (846 mm/s)

Operating Conditions and Usage		
<b>Accuracy:</b>		
Screw Lead Error	in/ft (µm / 300 mm)	0.001 (25)
Screw Travel Variation	in/ft (µm / 300 mm)	0.0012 (30)
Screw Lead Backlash	in	0.004 (T2X),
<b>Ambient Conditions:</b>		
Standard Ambient Temperature	°C	0 to 65
Extended Ambient Temperature**	°C	-40 to 65
Storage Temperature	°C	-40 to 85
IP Rating		T2X = IP65S R2M/R2G = IP65S R2M/G075 = IP66S
NEMA ratings	T2X090/R2M090 T2X115/R2M115	UL Type 4 UL Type 4
Vibration		2.5 g rms, 5 to 500 hz

\* Ratings for R2M075 at 40°C, operation over 40°C requires de-rating. Ratings for R2M090 and R2M115 at 25°C, operation over 25°C requires de-rating.

\*\*Consult Exlar for extended temperature operation.

## Communications & I/O

### Digital Inputs:

10 to 30 VDC Opto-isolated

### Digital Outputs:

30 VDC maximum  
100 mA continuous output Isolated

### Analog Input AC:

0-10V or +/-10V  
0-10V mode, 12 bit resolution  
+/-10V mode, 12 bit resolution on 90/115, Velocity, Torque, or Velocity Override commands.

### Analog Output AC:

0-10V  
12 bit resolution on 90/115

### IA4 option:

4-20 mA input  
16 bit resolution Isolated  
Assignable to Position, Velocity, or Torque command  
4-20 mA output  
12 bit resolution  
Assignable to Position, Velocity, Current, Temperature, etc

### Standard Communications:

- 1 RS485 port, Modbus RTU, opto-isolated for programming, controlling and monitoring

The IO count and type vary with the actuator model and option module selected.

All models include isolated digital IO, and an isolated RS485 communication port when using Modbus RTU protocol.

Tritex II AC I/O		
	90/115 mm frame with SIO, EIP, PIO, TCP	90/115 mm frame with IA4
Isolated digital inputs	8	8
Isolated digital outputs	4	4
Analog input, non isolated	1	1
Analog output, non isolated	1	1
Isolated 4-20ma input	0	1
Isolated 4-20ma output	0	1

## Product Features

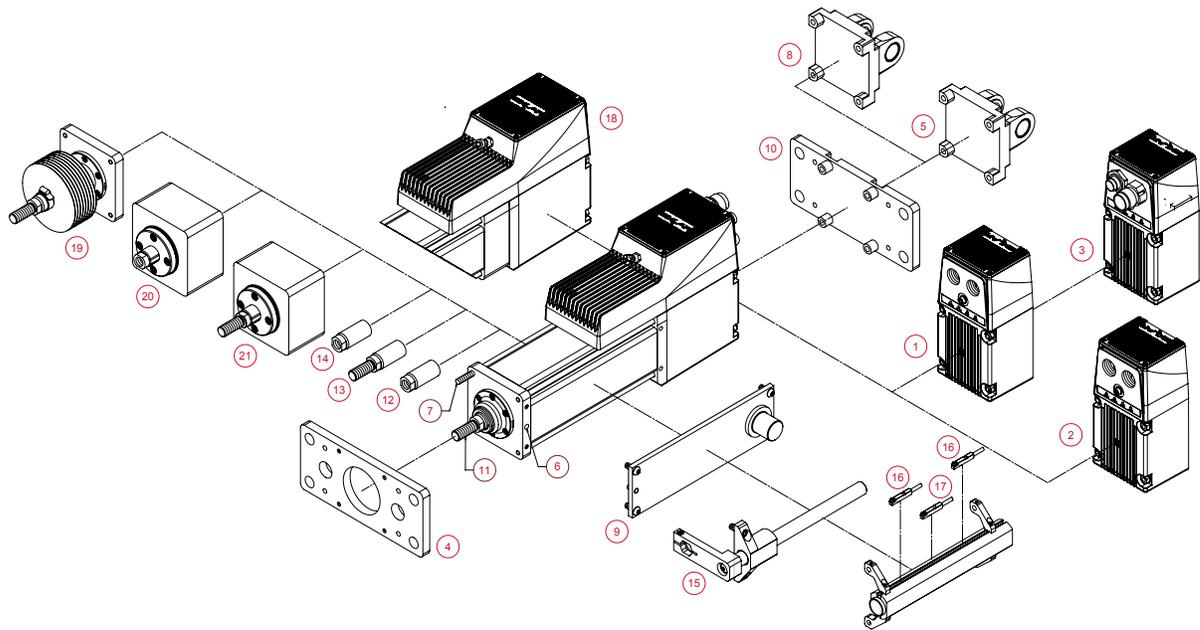
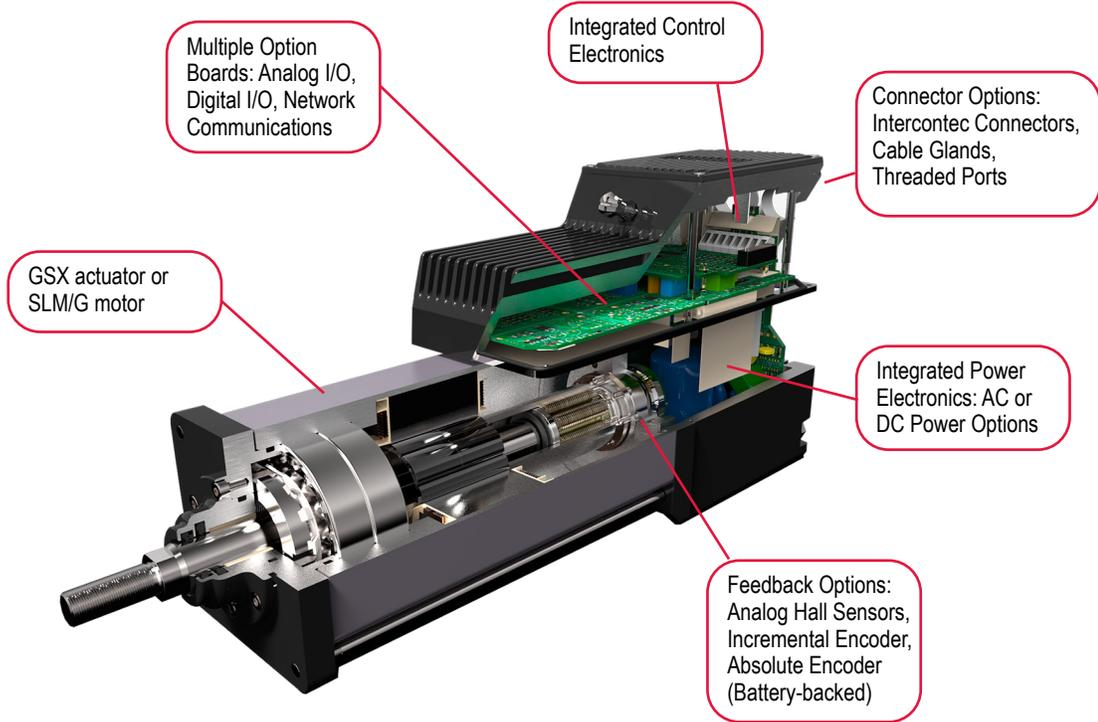

- 1 - Standard Straight Threaded Port with Internal terminals, M20 x 1.5
- 2 - NPT Threaded Port via Adapter with Internal Terminals, 1/2" NPT
- 3 - Intercontec Style - Exlar standard, M16/M23 Style Connector
- 4 - Front flange
- 5 - Rear clevis
- 6 - Double side mount and metric double side mount
- 7 - Extended tie rods and metric extended tie rods
- 8 - Metric rear clevis
- 9 - Side trunnion and metric side trunnion
- 10 - Rear flange
- 11 - Male, metric thread
- 12 - Female, metric thread
- 13 - Male, US standard thread
- 14 - Female, US standard thread
- 15 - External anti-rotate
- 16 - External limit switch - N.C., PNP
- 17 - External limit switch - N.O., PNP
- 18 - Rear brake
- 19 - Protective bellows
- 20 - Splined main rod - Female
- 21 - Splined main rod - Male

## Industries and Applications

Hydraulic cylinder replacement  
Ball screw replacement  
Pneumatic cylinder replacement

### Automotive

Clamping  
Dispensing  
Automated Assembly  
Flexible Tooling

### Food Processing

Depositing  
Slicing  
Diverters / Product Conveyance  
Sealing

### Process Control

Oil & Gas Wellhead Valve Control  
Pipeline Valve Control  
Damper Control  
Knife Valve Control  
Chemical pumps

### Entertainment / Simulation

Ride Motion Bases  
Animatronics

### Medical Equipment

Volumetric Pumps

### Plastics

Forming  
Part Eject  
Core Pull

### Material Handling

Robotic End Effectors  
Edge Guiding

Efficient food processing and packaging operations demand robust technologies that are powerful, durable, precise, and safe for food. Exlar products are ideal for these for harsh, high-capacity production environments

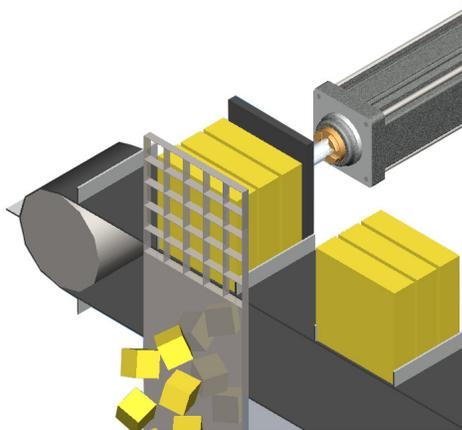

Exlar actuators can provide precision at high force loads for fluid dispensing in a medical environment.

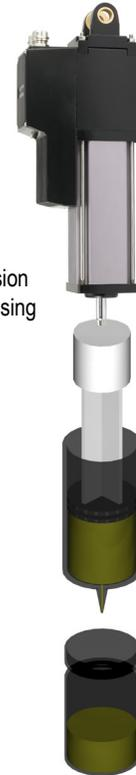

## Mechanical Specifications

### T2X090

	Stator	1 Stack	2 Stack	2 Stack	
Lead	RPM @ 240 VAC	4000	4000	3000	
0.1	Continuous Force	lbf (N)	1,130 (5062)	1,488 (6619)	NA
	Peak Force	lbf (N)	2,260 (10053)	2,700 (12010)***	NA
	Max Speed	in/sec (mm/sec)	6.67 (169)	6.67 (169)	NA
	T2X - C <sub>a</sub> (Dynamic Load Rating)	lbf (N)	5516 (24536)		NA
0.2	Continuous Force	lbf (N)	640 (2847)	843 (3750)	1,113 (4951)
	Peak Force	lbf (N)	1,281 (5698)	1,687 (7504)	2,225 (9897)
	Max Speed	in/sec (mm/sec)	13.33 (338)	13.33 (338)	10.00 (254)
	T2X - C <sub>a</sub> (Dynamic Load Rating)	lbf (N)	5800 (25798)		
0.5	Continuous Force	lbf (N)	271 (1205)	357 (1588)	471 (2095)
	Peak Force	lbf (N)	542 (2410)	714 (3176)	942 (4190)
	Max Speed	in/sec (mm/sec)	33.33 (847)	33.33 (847)	25.00 (635)
	T2X - C <sub>a</sub> (Dynamic Load Rating)	lbf (N)	4900 (21795)		
Drive Current @ Continuous Force	Amps	5.7	7.5	7.5	
Available Stroke Lengths	in (mm)	3 (75), 6 (150), 10 (254), 12 (300), 18 (450)			
Inertia (zero stroke)	lb-in-s <sup>2</sup> / Kg-m <sup>2</sup>	0.002655 (0.000003000)	0.002829 (0.000003196)	0.003003 (0.0000033963)	
Inertia Adder (per inch of stroke)	lb-in-s <sup>2</sup> /in/ Kg-m <sup>2</sup> /in	0.0001424 (0.0000001609)			
Approximate Weight	lb (kg)	14 (6.35) for 3 inch stroke, 1 stack. Add 1 (0.5) per inch of stroke. Add 3 (1.4) per motor stack. Add 3 (1.4) for brake.			
Operating Temperature Range <sup>1</sup>		-20 to 65° C (-40° C available, consult Exlar)			
Continuous AC Input Current <sup>2</sup>	Amps	6.3	6.3	6.3	
Rear Brake Current Draw		0.67 Amps @ 24 VDC			

\* Ratings based on 25°C conditions. \*\* Continuous input current rating is defined by UL and CSA. \*\*\* T2X peak force for 0.1 inch lead is 2700 lbf (12010 N)

### T2X115

	Stator	1 Stack	2 Stack	2 Stack	
Lead	RPM @ 240 VAC	3000	2000	1500	
0.1	Continuous Force	lbf (N)	2,060 (9,163)	3,224 (14,341)	NA
	Peak Force	lbf (N)	4,120 (18,327)	5,400 (24,020)***	NA
	Max Speed	in/sec (mm/sec)	5.00 (127)	3.33 (84)	NA
	T2X - C <sub>a</sub> (Dynamic Load Rating)	lbf (N)	7900 (35141)		NA
0.2	Continuous Force	lbf (N)	1,177 (5,235)	1,843 (8,198)	2,380 (10,586)
	Peak Force	lbf (N)	2,354 (10,471)	3,685 (16,392)	4,760 (21,174)
	Max Speed	in/sec (mm/sec)	10.00 (254)	6.67 (169)	5.00 (127)
	T2X - C <sub>a</sub> (Dynamic Load Rating)	lbf (N)	8300 (36920)		
0.5	Continuous Force	lbf (N)	530 (2,358)	829 (3,688)	1,071 (4,764)
	Peak Force	lbf (N)	1,059 (4711)	1,658 (7,375)	2,142 (9,528)
	Max Speed	in/sec (mm/sec)	25.00 (635)	16.67 (423)	12.50 (317)
	T2X - C <sub>a</sub> (Dynamic Load Rating)	lbf (N)	7030 (31271)		
0.75	Continuous Force	lbf (N)	353 (1,570)	553 (2,460)	714 (3,176)
	Peak Force	lbf (N)	706 (3,140)	1,106 (4,920)	1,428 (6,352)
	Max Speed	in/sec (mm/sec)	37.5 (953)	25 (635)	17.75 (450)
	T2X - C <sub>a</sub> (Dynamic Load Rating)	lbf (N)	6335 (28179)		
Drive Current @ Continuous Force	Amps	8.5	8.5	8.5	
Available Stroke Lengths	in (mm)	4 (102), 6 (150), 10 (254), 12 (300), 18 (450)			
Inertia (zero stroke)	lb-in-s <sup>2</sup> / Kg-m <sup>2</sup>	0.01132 (0.000012790)	0.01232 (0.00001392)	0.01332 (0.00001505)	
Inertia Adder (per inch of stroke)	lb-in-s <sup>2</sup> /in/ Kg-m <sup>2</sup> /in	0.0005640 (0.0000006372)			
Approximate Weight	lb (kg)	34 (15.5) for 6 inch stroke, 1 stack. Add 2 (1) per inch of stroke. Add 8 (4) per motor stack. Add 4 (2) for brake.			
Operating Temperature Range <sup>1</sup>		-20 to 65° C (-40° C available, consult Exlar)			
Continuous AC Input Current <sup>2</sup>	Amps	8.3	8.3	8.3	
Rear Brake Current Draw		0.75 Amps @ 24 VDC			

\* Ratings based on 25°C conditions. \*\* Continuous input current rating is defined by UL and CSA. \*\*\* T2X peak force for 0.1 inch lead is 5400 lbf (24020 N)

## Estimated Service Life

T2X090 Estimated L<sub>10</sub> Travel Life

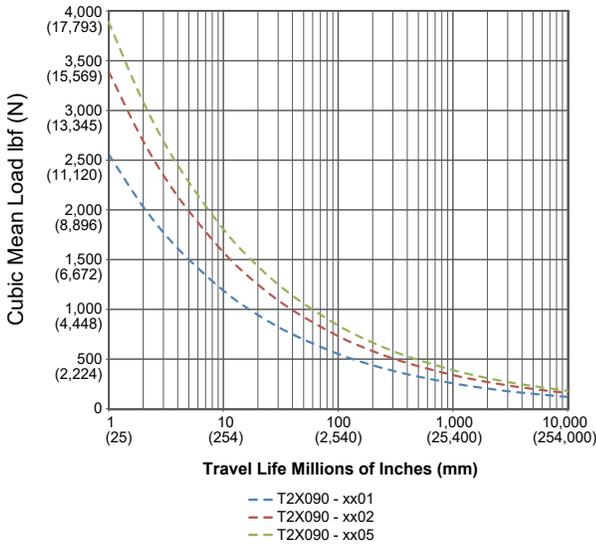

T2X115 Estimated L<sub>10</sub> Travel Life

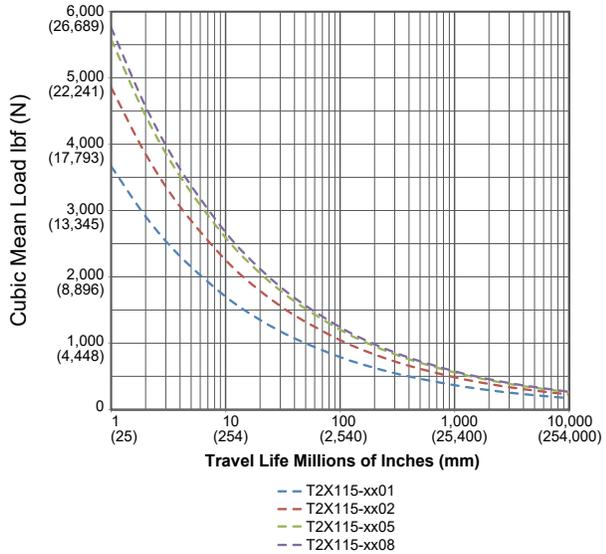

The L<sub>10</sub> expected life of a roller screw linear actuator is expressed as the linear travel distance that 90% of properly maintained roller screws are expected to meet or exceed. For higher than 90% reliability, the result should be multiplied by the following factors: 95% x 0.62; 96% x 0.53; 97% x 0.44; 98% x 0.33; 99% x 0.21. This is not a guarantee; these charts should be used for estimation purposes only.

The underlying formula that defines this value is: Travel life in millions of inches, where:

- C<sub>a</sub> = Dynamic load rating (lbf)
- F<sub>cmf</sub> = Cubic mean applied load (lbf)
- ℓ = Roller screw lead (inches)

$$L_{10} = \left( \frac{C_a}{F_{cmf}} \right)^3 \times \ell$$

All curves represent properly lubricated and maintained actuators.

## Speed vs. Force Curves

### Temperature Derating

The speed/torque curves are based on 25° C ambient conditions. The actuators may be operated at ambient temperatures up to 65° C. Use the curve (shown right) for continuous torque/force deratings above 25° C.

#### DEFINITIONS:

**Continuous Force:** The linear force produced by the actuator at continuous motor torque.

**Peak Force:** The linear force produced by the actuator at peak motor torque.

**Max Speed:** The maximum rated speed produced by the actuator at rated voltage.

**C<sub>a</sub> (Dynamic Load Rating):** A design constant used in calculating the estimated travel life of the roller screw.

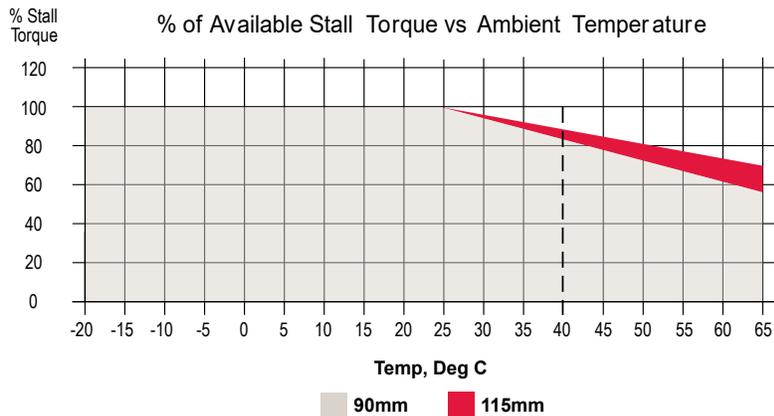

**T2X090 (1 Stack)\***

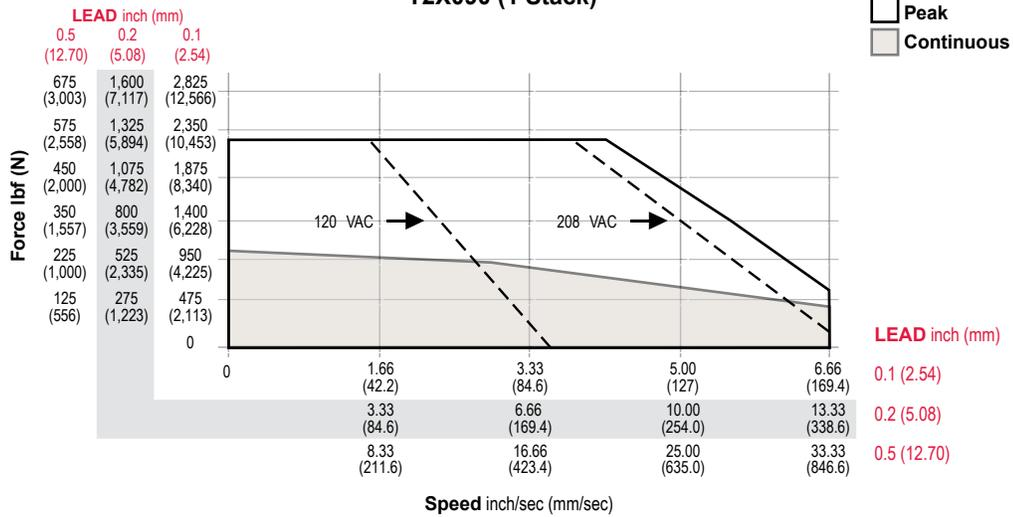

**T2X090 (2 Stack, 4000 rpm)\***

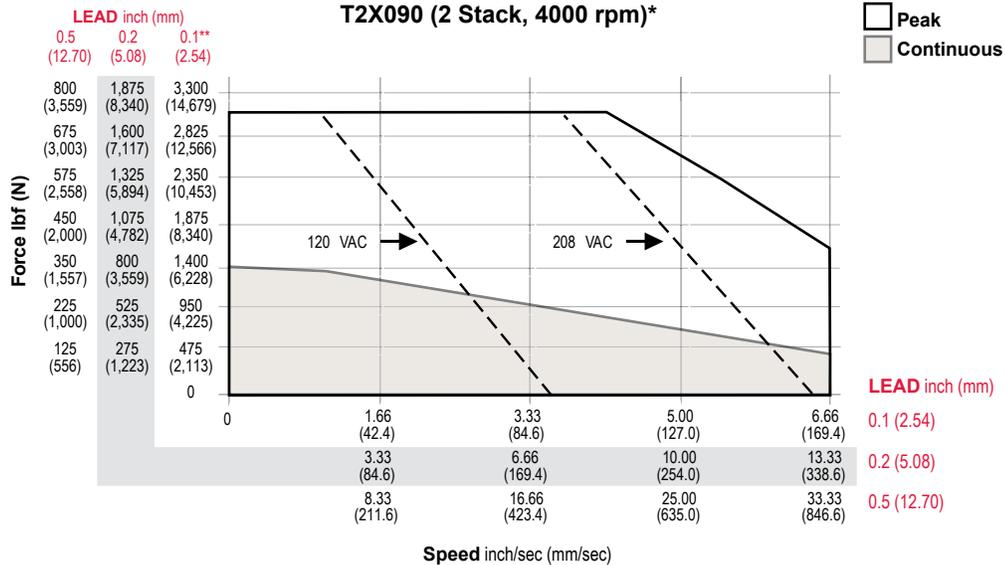

\*\*T2X peak force for 0.1 inch lead is 2700 lbf (12010 N).

**T2X090 (2 Stack, 3000 rpm)\***

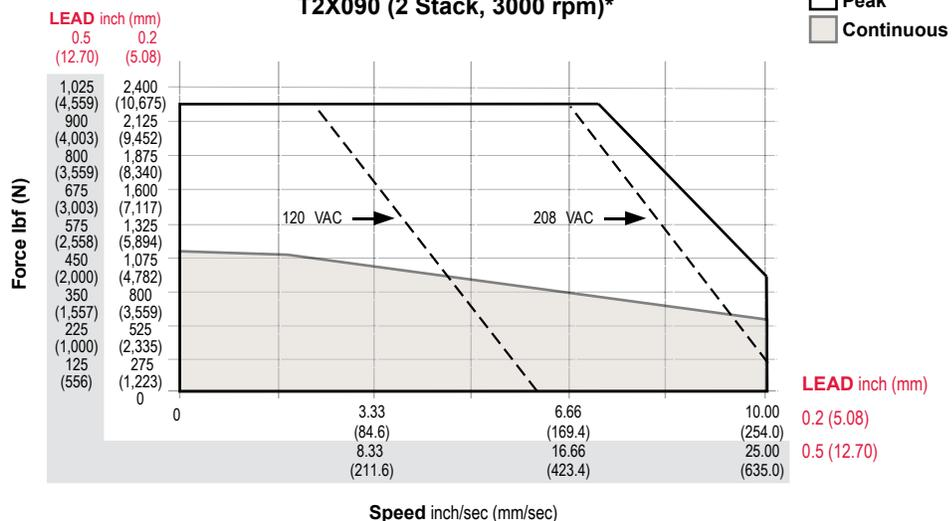

\*Test data derived using NEMA recommended aluminum heatsink 10" x 10" x 3/8" at 25°C ambient.

### T2X115 (1 Stack)\*

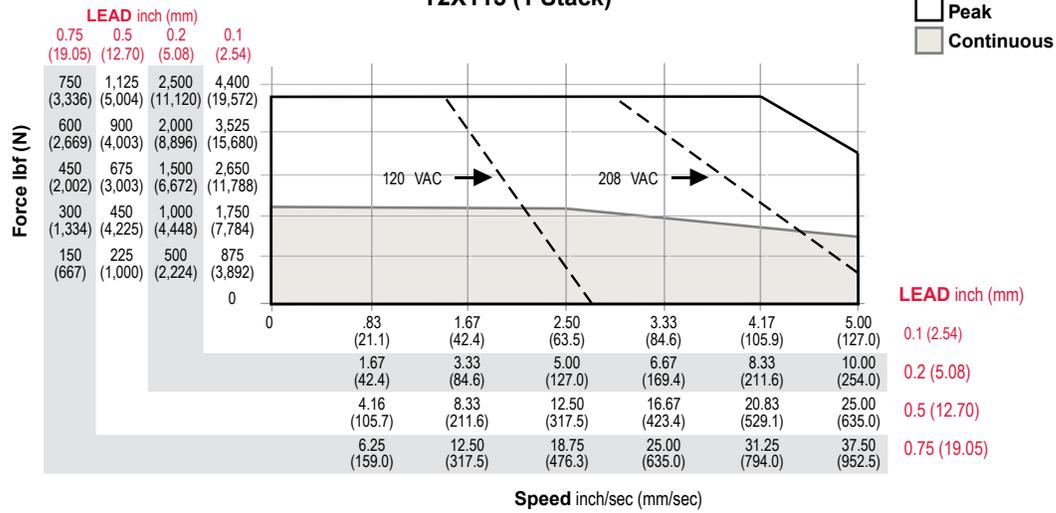

### T2X115 (2 Stack, 2000 rpm)\*

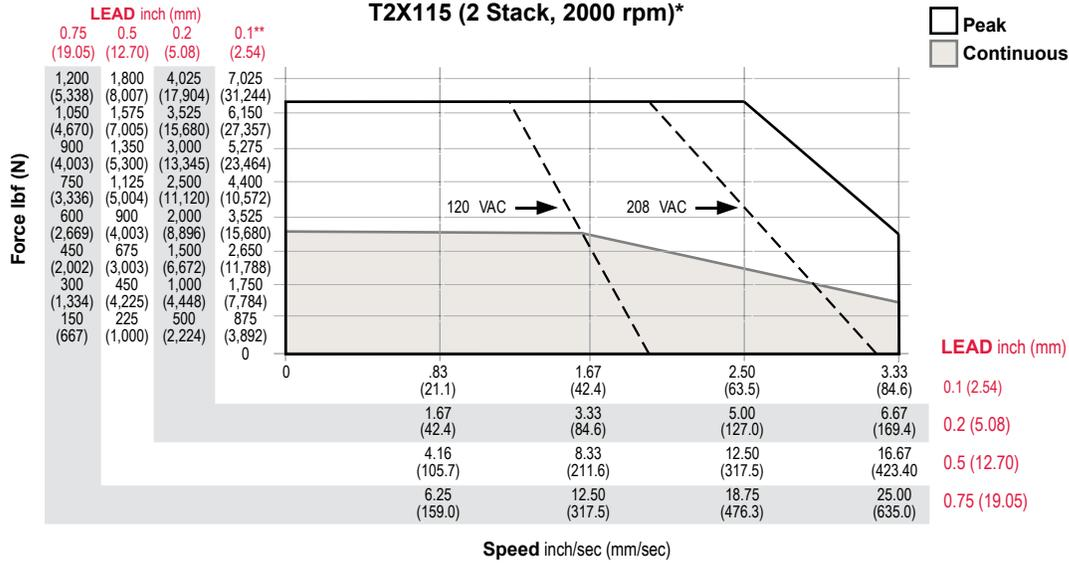

\*\*T2X peak force for 0.1 inch lead is 5400 lbf (24020 N).

### T2X115 (2 Stack, 1500 rpm)\*

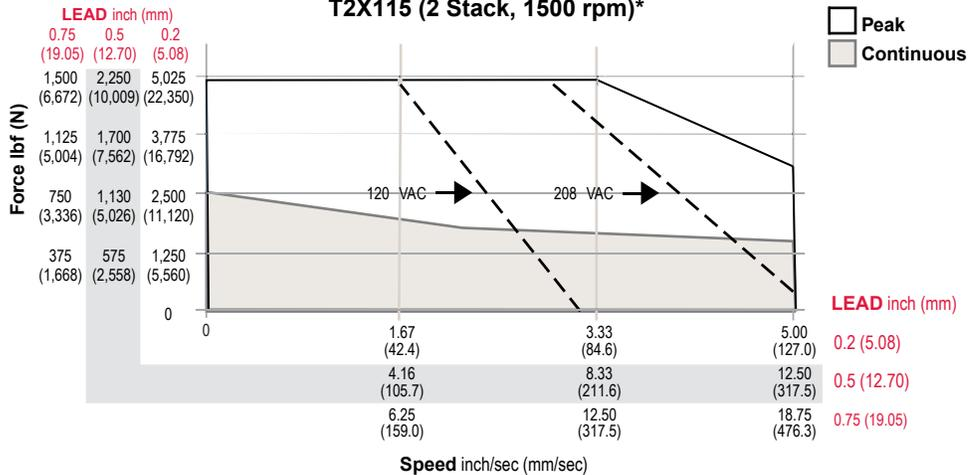

\*Test data derived using NEMA recommended aluminum heatsink 12" x 12" x 1/2" at 25°C ambient.

## Options

### **AR = External Anti-rotate Assembly**

This option provides a rod and bushing to restrict the actuator rod from rotating when the load is not held by another method. Shorter actuators have single sided anti-rotation attachments. Longer lengths require attachments on both sides for proper operation.

### **L1, L2, L3 = Adjustable External Travel Switches**

This option allows up to 3 external switches to be included. These switches provide travel indication to the controller and are adjustable. Must purchase external anti-rotate with this option.

### **PB = Protective Bellows**

This option provides an accordion style protective bellows to protect the main actuator rod from damage due to abrasives or other contaminants in the environment in which the actuator must survive. The standard material of this bellows is S2 Neoprene Coated Nylon, Sewn Construction. This standard bellows is rated for environmental temperatures of -40 to 250 degrees F. Longer strokes may require the

main rod of the actuator to be extended beyond standard length. Not available with extended tie rod mounting option. Please contact your local sales representative.

### **RB = Rear Electric Brake**

This option provides an internal holding brake. The brake is spring activated and electrically released.

### **SR = Splined Main Rod**

A ball spline shafting main rod with a ball spline nut that replaces the standard front seal and bushing assembly. This rod restricts rotation without the need for an external mechanism. The rod diameter will be the closest metric equivalent to our standard rod sizes. Since this option is NOT sealed, it is not suitable for environments in which contaminants may enter the actuator.

Note: Adding this option affects the overall length and mounting dimensions.



### T2X115 Double Side Mount or Extended Tie Rod Mount

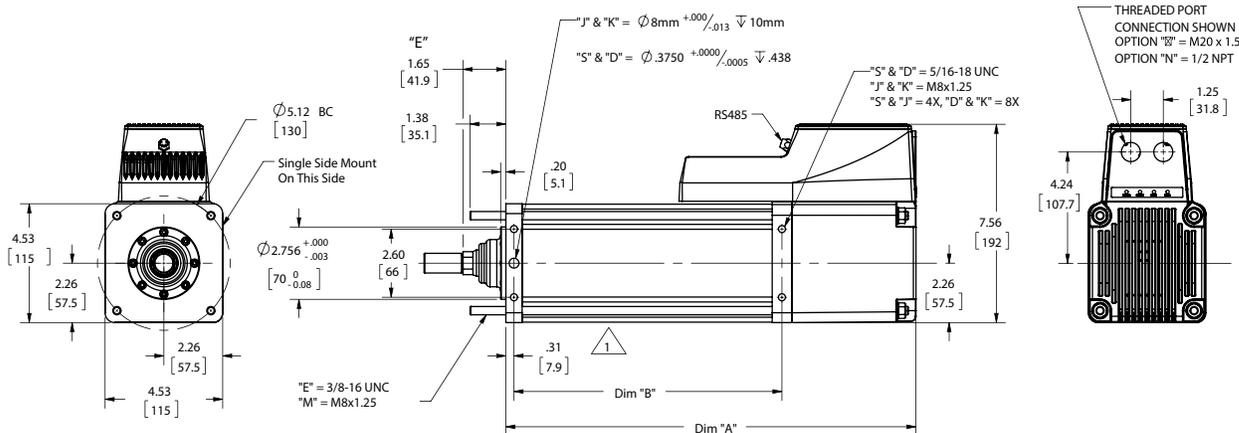

### T2X115 Side Trunnion Mount or Rear Clevis Mount

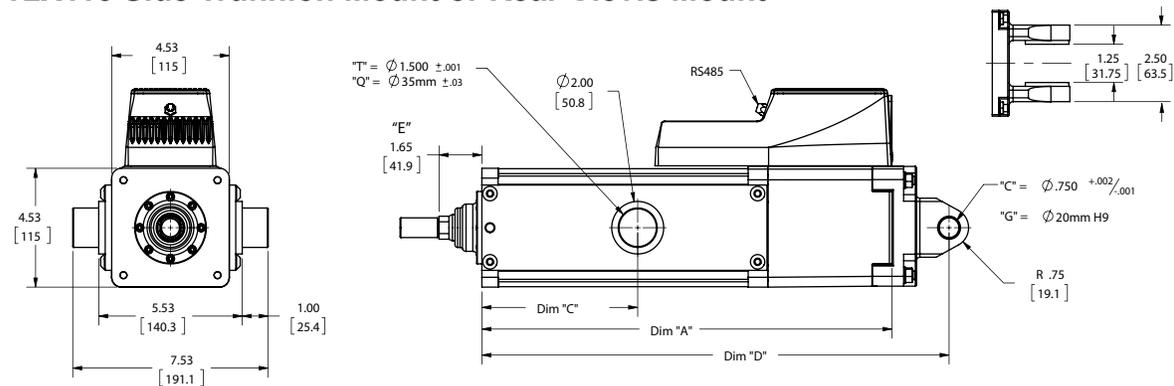

### T2X115 Front, Rear, or Front and Rear Flange Mount

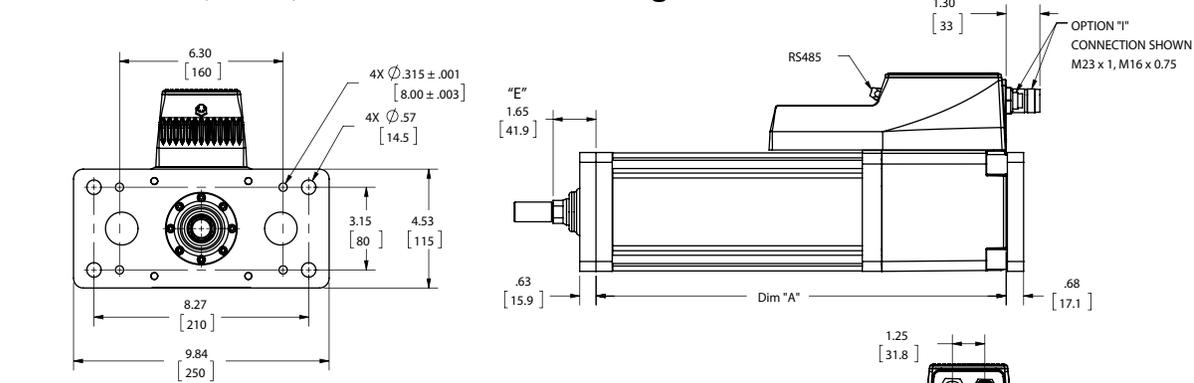

DIM	4 in (102 mm) stroke in (mm)	6 in (152 mm) stroke in (mm)	10 in (254 mm) stroke in (mm)	12 in (305 mm) stroke in (mm)	18 in (457 mm) stroke in (mm)
A	13.79 (350.3)	15.79 (401.1)	19.79 (502.7)	21.79 (553.5)	27.79 (705.9)
B	8.31 (211.1)	10.31 (261.8)	14.31 (363.5)	16.31 (414.3)	22.31 (566.7)
C	4.00 (101.6)	6.00 (152.4)	10.00 (254.0)	12.00 (304.8)	18.00 (457.2)
D	15.99 (406.1)	17.99 (456.9)	21.99 (558.5)	23.99 (609.3)	29.99 (761.7)

\* Add 2.33 inches to dimensions "A", "B" and "D" if ordering a brake. Add 1.77 inches to dimensions "A", "C" and "D" and dimension if ordering a splined main rod.  
 \*\*Add 2 in (50.8 mm) to dimension "E" if ordering protective bellows.

Pre-sale drawings and models are representative and are subject to change. Certified drawings and models are available for a fee. Consult your local Exlar representative for details.

## Anti-Rotate Option

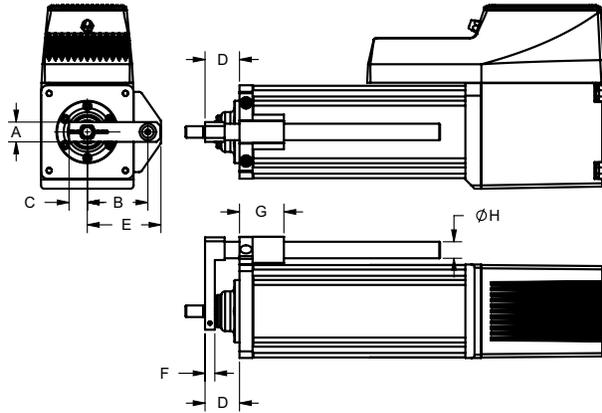

DIM in (mm)	T2X090	T2X115
A	0.75 (19.1)	1.13 (28.7)
B	2.32 (58.9)	3.06 (77.7)
C	0.70 (17.8)	1.00 (25.4)
D	1.32 (33.5)	1.65 (41.9)
E	2.82 (71.6)	3.63 (92.2)
F	0.38 (9.7)	0.50 (12.7)
G	1.70 (43.2)	1.97 (50.0)
ØH	0.63 (16.0)	0.75 (19.1)

## Actuator Rod End Option

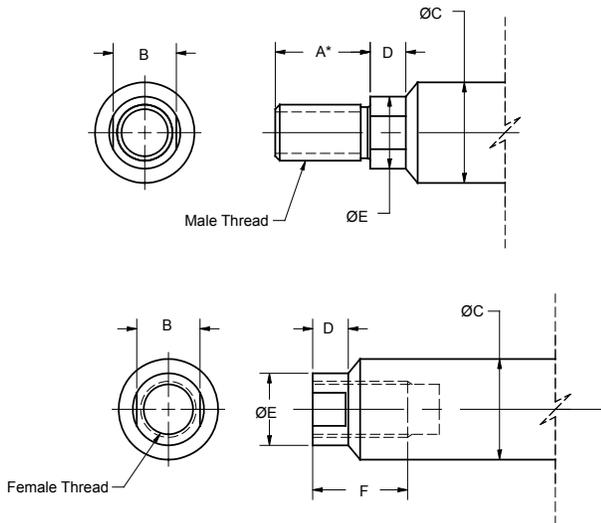

DIM in (mm)	T2X090	T2X115
A*	1.250 (31.8)	1.500 (38.1)
B	0.625 (17.0)	0.750 (19.1)
ØC	0.787 (20.0)	1.000 (25.4)
D	0.281 (7.1)	0.381 (9.7)
ØE	0.725 (18.4)	0.875 (22.2)
F	1.000 (25.4)	1.000 (25.4)
Male-Inch "M"	1/2-20 UNF-2A	3/4-16 UNF-2A
Male-Metric "A"	M16 x 1.5 6g	M16 x 1.5 6g
Female-Inch "F"	1/2-20 UNF-2B	5/8-18 UNF-2B
Female-Metric "B"	M16 x 1.5 6H	M16 x 1.5 6H

\*When ordering the male M12x1.75 main rod for the T2M/X075 dimension "A" will be 1.57 in (40 mm)

## Clevis Pin

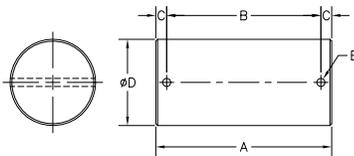

	T2X090	T2X090	T2X115
	CP050 Fits Rod Eye, Rod Clevis in (mm)	CP075 Fits Rear Clevis in (mm)	CP075 Fits Rod Eye, Rod Clevis, Spherical Eye, Rear Clevis in (mm)
A	2.28 (57.9)	3.09 (78.5)	3.09 (78.5)
B	1.94 (49.28)	2.72 (69.1)	2.72 (69.1)
C	0.17 (4.32)	0.19 (4.82)	1.19 (4.82)
ØD	0.50 -0.001/-0.002 (12.7 mm +0.00/-0.05)	0.75 -0.001/-0.002 (19.1 mm +0.00/-0.05)	0.75 -0.001/-0.002 (19.1 mm +0.00/-0.05)
ØE	0.106 (2.69)	0.14 (3.56)	0.14 (3.56)

Pre-sale drawings and models are representative and are subject to change. Certified drawings and models are available for a fee. Consult your local Exlar representative for details.

### Spherical Rod Eye

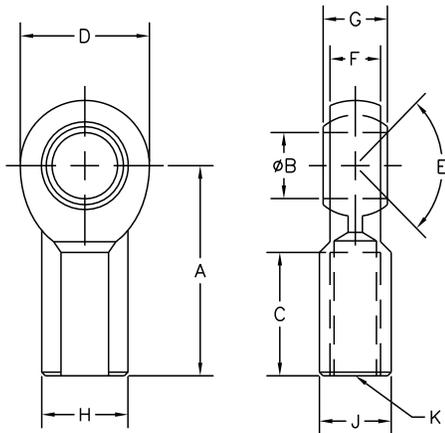

DIM in (mm)	T2X090	T2X115
	SRM050	SRM075
A	2.125 (54.0)	2.88 (73.2)
ØB	0.500 (12.7)	0.75 (19.1)
C	1.156 (29.4)	1.72 (43.7)
D	1.312 (33.3)	1.75 (44.5)
E	6 Deg	14 Deg
F	0.500 (12.7)	0.69 (17.5)
G	0.625 (15.9)	0.88 (22.3)
H	0.875 (22.2)	1.13 (28.7)
J	0.750 (19.1)	1.00 (25.4)
K	1/2-20	3/4-16

### Rod Eye

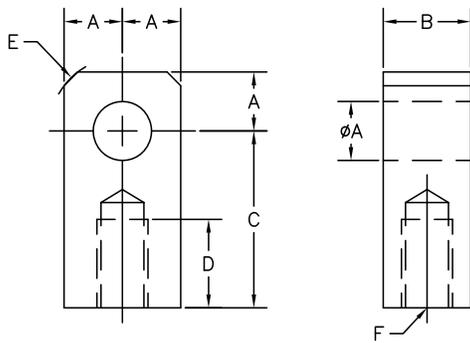

DIM in (mm)	T2X090	T2X115
	REI050	RE075
ØA	0.50 (12.7)	0.75 (19.05)
B	0.75 (19.05)	1.25 (31.8)
C	1.50 (38.1)	2.06 (52.3)
D	0.75 (19.05)	1.13 (28.7)
E	0.375 (9.53)	0.88 (22.2)
F	1/2-20	3/4-16

### Rod Clevis

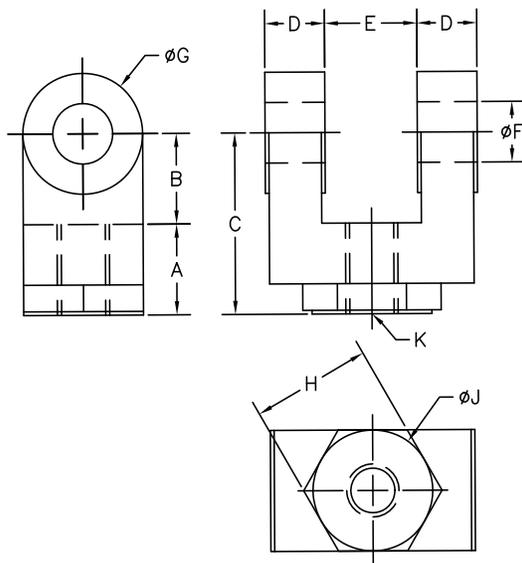

DIM in (mm)	T2X090	T2X115
	RCI050	RC075
A	0.750 (19.05)	1.125 (28.58)
B	0.750 (19.05)	1.25 (31.75)
C	1.500 (38.1)	2.375 (60.3)
D	0.500 (12.7)	0.625 (15.88)
E	0.765 (19.43)	1.265 (32.12)
ØF	0.500 (12.7)	0.75 (19.1)
ØG	1.000 (25.4)	1.50 (38.1)
H	1.000 (25.4)	1.25 (31.75)
ØJ	N/A	1.25 (31.75)
K	1/2-20	3/4-16

Pre-sale drawings and models are representative and are subject to change. Certified drawings and models are available for a fee. Consult your local Exlar representative for details.

## Mechanical Specifications

### R2M/G075

Rotary Motor Torque and Speed Ratings				
	Stator	1 Stack	2 Stack	3 Stack
RPM at 240 VAC		4000	3000	2000
Continuous Torque	lbf-in (Nm)	13 (1.47)	21 (2.37)	28 (3.16)
Peak Torque	lbf-in (Nm)	25 (2.8)	42 (4.75)	56 (6.33)
Drive Current @ Continuous Torque	Amps	3.1	3.8	3.8
Operating Temperature Range*	-20 to 65° C (-40°C available, consult Exlar)			
Continuous AC Input Current**	Amps	4.3	4	3.6

\*Ratings based on 40° C ambient conditions.

\*\*Continuous input current rating is defined by UL and CSA.

For output torque of R2G gearmotors, multiply by ratio and efficiency. Please note maximum allowable output torques shown below.

Inertia				
	Stator	1 Stack	2 Stack	3 Stack
R2M Motor Armature Inertia (+/-5%)	lb-in-sec <sup>2</sup> (kg-cm <sup>2</sup> )	0.000545 (0.6158)	0.000973 (1.0996)	0.001401 (1.5834)
R2G Gearmotor Armature Inertia* (+/-5%)	lb-in-sec <sup>2</sup> (kg-cm <sup>2</sup> )	0.000660 (0.7450)	0.001068 (1.2057)	0.001494 (1.6868)

\*Add armature inertia to gearing inertia for total R2G system inertia.

L <sub>10</sub> Radial Load and Bearing Life							
RPM	50	100	250	500	1000	3000	
R2M075 lbf (N)	278 (1237)	220 (979)	162 (721)	129 (574)	102 (454)	71 (316)	
R2G075 lbf (N)	343 (1526)	272 (1210)	200 (890)	159 (707)	126 (560)	88 (391)	

Side load ratings shown above are for 10,000 hour bearing life at 25 mm from motor face at given rpm.

Gearmotor Mechanical Ratings					
Model	Ratio	Maximum Allowable Output Torque-Set by User lbf-in (Nm)	Output Torque at Motor Speed for 10,000 Hour Life		
			1000 RPM lbf-in (Nm)	2500 RPM lbf-in (Nm)	4000 RPM lbf-in (Nm)
R2G075-004	4:1	1618 (182.8)	384 (43.4)	292 (32.9)	254 (28.7)
R2G075-005	5:1	1446 (163.4)	395 (44.6)	300 (33.9)	260 (29.4)
R2G075-010	10:1	700 (79.1)	449 (50.7)	341 (38.5)	296 (33.9)

Two torque ratings for the R2G gearmotors are given in the table above. The left hand columns give the maximum (peak) allowable output torque for the indicated ratios of each size R2G gearmotor. This is not the rated output torque of the motor multiplied by the ratio of the reducer. It is possible to select a configuration of the motor selection and gear ratio such that the rated motor torque, multiplied by the gear ratio exceeds these ratings. It is the responsibility of the user to ensure that the settings of the system do not allow these values to be exceeded. The right hand columns give the output torque at the indicated speed which will result in 10,000 hour life (L10). The setup of the system will determine the actual output torque and speed.

Gearing Reflected Inertia		
Single Reduction		
Gear Stages	lbf-in-sec <sup>2</sup>	(kg-cm <sup>2</sup> )
4:1	0.000095	(0.107)
5:1	0.000062	(0.069)
10:1	0.000017	(0.019)

Backlash and Efficiency		
	Single Reduction	Double Reduction
Backlash at 1% Rated Torque	10 Arc min	13 Arc min
Efficiency	91%	86%

Motor and Gearmotor Weights			
	R2M075 without Gears	R2G075 with 1 Stage Gearing	Added Weight for Brake
1 Stack Stator lb (kg)	7.4 (3.4)	9.8 (4.4)	1.0 (0.5)
2 Stack Stator lb (kg)	9.2 (4.2)	11.6 (5.3)	
3 Stack Stator lb (kg)	11 (4.9)	13.4 (6.1)	

## R2M/G090

Rotary Motor Torque and Speed Ratings				
	Stator	2 Stack	2 Stack	3 Stack
	RPM at 240 VAC	4000	3000	2000
Continuous Torque	lbf-in (Nm)	30 (3.4)	40 (4.5)	52 (5.9)
Peak Torque	lbf-in (Nm)	60 (6.8)	80 (9.0)	105 (11.9)
Drive Current @ Continuous Torque	Amps	7.5	7.5	6.6
Operating Temperature Range <sup>†</sup>	-20 to 65° C (-40° C available, consult Exlar)			
Continuous AC Input Current <sup>**</sup>	Amps	6.3	6.3	6.3

\*Ratings based on 25° C ambient conditions.

\*\*Continuous input current rating is defined by UL and CSA.

For output torque of R2G gearmotors, multiply by ratio and efficiency. Please note maximum allowable output torques shown below.

Inertia			
	Stator	2 Stack	3 Stack
R2M Motor Armature Inertia (+/-5%)	lb-in-sec <sup>2</sup> (kg-cm <sup>2</sup> )	0.00097 (1.09)	0.00140 (1.58)
R2G Gearmotor Armature Inertia* (+/-5%)	lb-in-sec <sup>2</sup> (kg-cm <sup>2</sup> )	0.00157 (1.77)	0.00200 (2.26)

\*Add armature inertia to gearing inertia for total inertia.

L <sub>10</sub> Radial Load and Bearing Life							
RPM	50	100	250	500	1000	3000	
R2M090 lbf (N)	427 (1899)	340 (1512)	250 (1112)	198 (881)	158 (703)	109 (485)	
R2G090 lbf (N)	350 (1557)	278 (1237)	205 (912)	163 (725)	129 (574)	89 (396)	

Side load ratings shown above are for 10,000 hour bearing life at 25 mm from motor face at given rpm.

Gearmotor Mechanical Ratings					
Model	Ratio	Maximum Allowable Output Torque-Set by User lbf-in (Nm)	Output Torque at Motor Speed for 10,000 Hour Life		
			1000 RPM lbf-in (Nm)	2500 RPM lbf-in (Nm)	4000 RPM lbf-in (Nm)
R2G090-004	4:1	2078 (234.8)	698 (78.9)	530 (59.9)	460 (51.9)
R2G090-005	5:1	1798 (203.1)	896 (101.2)	680 (76.8)	591 (66.8)
R2G090-010	10:1	1126 (127.2)	1043 (117.8)	792 (89.4)	688 (77.7)
R2G090-016	16:1	2078 (234.8)	1057 (119.4)	803 (90.7)	698 (78.9)
R2G090-020	20:1	2078 (234.8)	1131 (127.8)	859 (97.1)	746 (84.3)
R2G090-025	25:1	1798 (203.1)	1452 (164.1)	1103 (124.6)	958 (108.2)
R2G090-040	40:1	2078 (234.8)	1392 (157.3)	1057 (119.4)	918 (103.7)
R2G090-050	50:1	1798 (203.1)	1787 (201.9)	1358 (153.4)	1179 (133.2)
R2G090-100	100:1	1126 (127.2)	1100 (124.3)	1100 (124.3)	1100 (124.3)

Two torque ratings for the R2G gearmotors are given in the table above. The left hand columns give the maximum (peak) allowable output torque for the indicated ratios of each size R2G gearmotor. This is not the rated output torque of the motor multiplied by the ratio of the reducer.

It is possible to select a configuration of the motor selection and gear ratio such that the rated motor torque, multiplied by the gear ratio exceeds these ratings. It is the responsibility of the user to ensure that the settings of the system do not allow these values to be exceeded.

The right hand columns give the output torque at the indicated speed which will result in 10,000 hour life (L10). The setup of the system will determine the actual output torque and speed.

Gearing Reflected Inertia					
Gear Stages	Single Reduction		Double Reduction		
	lbf-in-sec <sup>2</sup>	(kg-cm <sup>2</sup> )	Gear Stages	lbf-in-sec <sup>2</sup>	(kg-cm <sup>2</sup> )
4:1	0.000154	(0.174)	16:1	0.000115	(0.130)
5:1	0.000100	(0.113)	20:1, 25:1	0.0000756	(0.0854)
10:1	0.0000265	(0.0300)	40:1, 50:1, 100:1	0.0000203	(0.0230)

Backlash and Efficiency		
	Single Reduction	Double Reduction
Backlash at 1% Rated Torque	10 Arc min	13 Arc min
Efficiency	91%	86%

Motor and Gearmotor Weights				
	R2M090 without Gears	R2G090 with 1 Stage Gearing	R2G090 with 2 Stage Gearing	Added Weight for Brake
2 Stack Stator lb (kg)	14 (6.4)	22 (10)	25 (11.3)	1.5 (0.7)
3 Stack Stator lb (kg)	17 (7.7)	25 (11.3)	28 (12.7)	

## R2M/G115

Rotary Motor Torque and Speed Ratings				
	Stator	1 Stack	2 Stack	2 Stack
	RPM at 240 VAC	3000	2000	1500
Continuous Torque	lbf-in (Nm)	47 (5.3)	73 (8.3)	95 (10.7)
Peak Torque	lbf-in (Nm)	94 (10.6)	146 (16.5)	190 (21.5)
Drive Current @ Continuous Torque	Amps	8.5	8.5	8.5
Operating Temperature Range <sup>†</sup>	-20 to 65° C (-40° C available, consult Exlar)			
Continuous AC Input Current <sup>**</sup>	Amps	8.3	8.3	8.3

<sup>†</sup>Ratings based on 25° C ambient conditions.

<sup>\*\*</sup>Continuous input current rating is defined by UL and CSA.

For output torque of R2G gearmotors, multiply by ratio and efficiency. Please note maximum allowable output torques shown below.

Inertia			
	Stator	1 Stack	2 Stack
R2M Motor Armature Inertia (+/-5%)	lb-in-sec <sup>2</sup> (kg-cm <sup>2</sup> )	0.00344 (3.89)	0.00623 (7.036)
R2G Gearmotor Armature Inertia*	lb-in-sec <sup>2</sup> (kg-cm <sup>2</sup> )	0.00538 (6.08)	0.00816 (9.22)

\*Add armature inertia to gearing inertia for total R2M system inertia.

L <sub>10</sub> Radial Load and Bearing Life							
RPM	50	100	250	500	1000	3000	
R2M115 lbf (N)	579 (2576)	460 (2046)	339 (1508)	269 (1197)	214 (952)	148 (658)	
R2G115 lbf (N)	858 (3817)	681 (3029)	502 (2233)	398 (1770)	316 (1406)	218 (970)	

Side load ratings shown above are for 10,000 hour bearing life at 25 mm from motor face at given rpm.

Gearmotor Mechanical Ratings					
Model	Ratio	Maximum Allowable Output Torque-Set by User lbf-in (Nm)	Output Torque at Motor Speed for 10,000 Hour Life		
			1000 RPM lbf-in (Nm)	2000 RPM lbf-in (Nm)	3000 RPM lbf-in (Nm)
R2G115-004	4:1	4696 (530.4)	1392 (157.3)	1132 (127.9)	1000 (112.9)
R2G115-005	5:1	4066 (459.4)	1455 (163.3)	1175 (132.8)	1040 (117.5)
R2G115-010	10:1	2545 (287.5)	1660 (187.6)	1350 (152.6)	1200 (135.6)
R2G115-016	16:1	4696 (530.4)	2112 (238.6)	1714 (193.0)	1518 (171.0)
R2G115-020	20:1	4696 (530.4)	2240 (253.1)	1840 (207.9)	1620 (183.0)
R2G115-025	25:1	4066 (459.4)	2350 (265.5)	1900 (214.7)	1675 (189.2)
R2G115-040	40:1	4696 (530.4)	2800 (316.4)	2240 (253.1)	2000 (225.9)
R2G115-050	50:1	4066 (459.4)	2900 (327.7)	2350 (265.5)	2100 (237.3)
R2G115-100	100:1	2545 (287.5)	2500 (282.5)	2500 (282.5)	2400 (271.2)

Two torque ratings for the R2G gearmotors are given in the table above. The left hand columns give the maximum (peak) allowable output torque for the indicated ratios of each size R2G gearmotor. This is not the rated output torque of the motor multiplied by the ratio of the reducer.

It is possible to select a configuration of the motor selection and gear ratio such that the rated motor torque, multiplied by the gear ratio exceeds these ratings. It is the responsibility of the user to ensure that the settings of the system do not allow these values to be exceeded.

The right hand columns give the output torque at the indicated speed which will result in 10,000 hour life (L10). The setup of the system will determine the actual output torque and speed.

Gearing Reflected Inertia					
Single Reduction			Double Reduction		
Gear Stages	lbf-in-sec <sup>2</sup>	(kg-cm <sup>2</sup> )	Gear Stages	lbf-in-sec <sup>2</sup>	(kg-cm <sup>2</sup> )
4:1	0.000635	(0.717)	16:1	0.000513	(0.580)
5:1	0.000428	(0.484)	20:1, 25:1	0.000350	(0.396)
10:1	0.000111	(0.125)	40:1, 50:1, 100:1	0.0000911	(0.103)

Backlash and Efficiency		
	Single Reduction	Double Reduction
Backlash at 1% Rated Torque	10 Arc min	13 Arc min
Efficiency	91%	86%

Motor and RTG115 Gearmotor Weights				
	R2M115 without Gears	R2G115 with 1 Stage Gearing	R2G115 with 2 Stage Gearing	Added Weight for Brake
1 Stack Stator lb (kg)	19 (8.6)	34 (15.4)	40 (18.1)	2.7 (1.2)
2 Stack Stator lb (kg)	27 (12.2)	42 (19.1)	48 (21.8)	
3 Stack Stator lb (kg)	35 (15.9)	50 (22.7)	56 (25.4)	

## Speed vs. Torque Curves

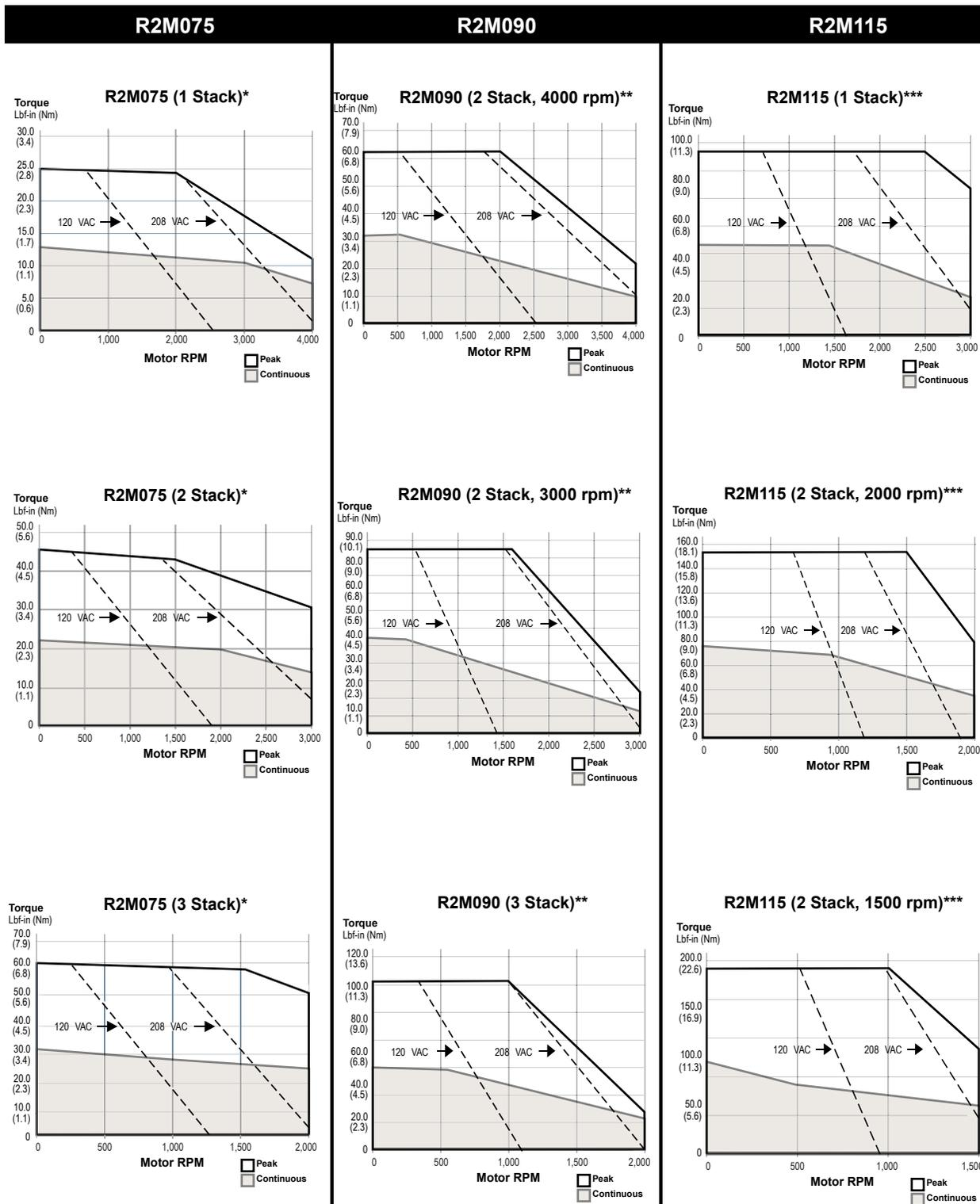

For R2G gearmotors, multiply torque by gear ratio and efficiency. Divide speed by gear ratio efficiencies; 1 Stage = 0.91, 2 Stage = 0.86

\*R2M075 test data derived using NEMA recommended aluminum heatsink 10" x 10" x 3/8" at 40°C ambient.

\*\*R2M090 test data derived using NEMA recommended aluminum heatsink 10" x 10" x 3/8" at 25°C ambient.

\*\*\*R2M115 test data derived using NEMA recommended aluminum heatsink 12" x 12" x 1/2" at 25°C ambient.

## Dimensions

### R2M/G075 Base Actuator

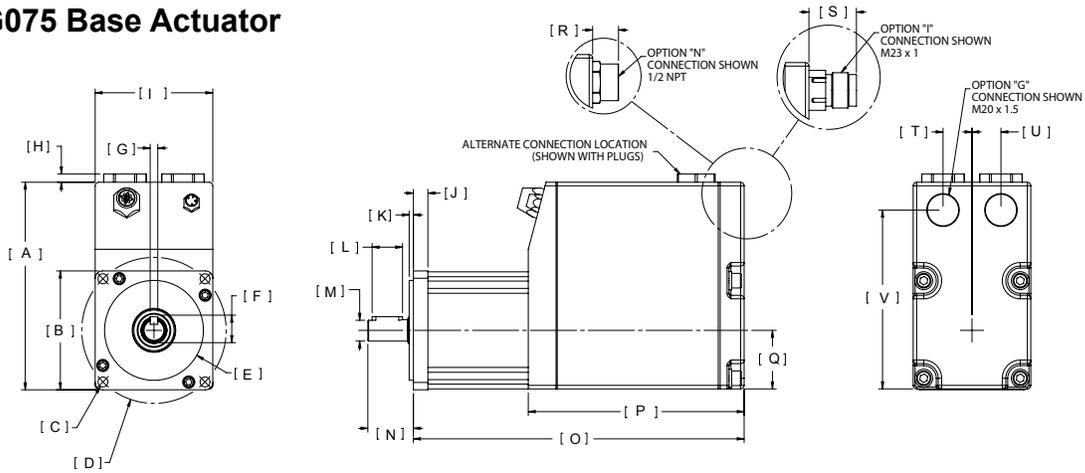

		R2M075	R2G075			R2M075	R2G075
A	in	5.32	5.32	L	in	0.79	0.79
	mm	135.1	135.1		mm	20.0	20.0
B	in	□ 3.05	□ 3.05	M	in	∅ 0.5512 / 0.5508	∅ 0.6302 / 0.6298
	mm	77.4	77.4		mm	14 h6	16 j6
C	in	4X ∅ 0.26 ON BC	4X ∅ 0.26 ON BC	N	in	1.18	1.18
	mm	6.5	6.5		mm	30.0	30.0
D	in	∅ 3.74 BC	∅ 3.74 BC	O	in	See Below	See Below
	mm	95.0	95.0		mm	See Below	See Below
E	in	∅ 2.5587 / 2.5580	∅ 2.5587 / 2.5580	P	in	5.59	5.59
	mm	65 g6	65 g6		mm	142.0	142.0
F	in	0.70	0.70	Q	in	1.50	1.50
	mm	17.9	17.9		mm	38.1	38.1
G	in	∅ 0.1969 / 0.1957	∅ 0.1969 / 0.1957	R	in	0.67	0.67
	mm	5 h9	5 h9		mm	17.0	17.0
H	in	0.21	0.21	S	in	1.23	1.23
	mm	5.3	5.3		mm	31.3	31.3
I	in	3.05	3.05	T	in	0.75	0.75
	mm	77.4	77.4		mm	19.1	19.1
J	in	0.38	0.45	U	in	0.75	0.75
	mm	9.5	11.5		mm	19.1	19.1
K	in	0.11	0.11	V	in	4.58	4.58
	mm	2.8	2.8		mm	116.4	116.4

### R2M075

With Brake Option			
DIM	1 Stack Stator	2 Stack Stator	3 Stack Stator
O	9.85 (250.2)	10.85 (275.6)	11.85 (301.0)

Without Brake Option			
DIM	1 Stack Stator	2 Stack Stator	3 Stack Stator
O	8.57 (217.7)	9.57 (243.1)	10.57 (268.5)

### R2G075

Without Brake Option			
DIM	1 Stack Stator 1 Stage Gearhead	2 Stack Stator 1 Stage Gearhead	3 Stack Stator 1 Stage Gearhead
O	10.19 (258.8)	11.19 (284.2)	12.19 (309.6)

With Brake Option			
DIM	1 Stack Stator 1 Stage Gearhead	2 Stack Stator 1 Stage Gearhead	3 Stack Stator 1 Stage Gearhead
O	11.42 (290.1)	12.42 (315.5)	13.42 (340.9)

Pre-sale drawings and models are representative and are subject to change. Certified drawings and models are available for a fee. Consult your local Exlar representative for details.

## R2M/G090 Base Actuator

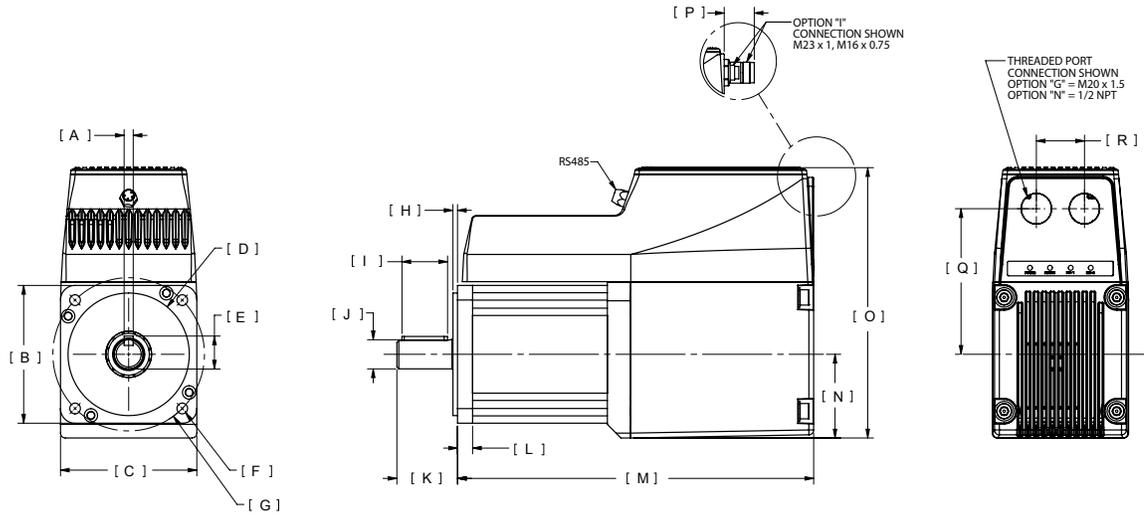

		R2M090	R2G090			R2M090	R2G090
<b>A</b>	in	0.2360 / 0.2348	0.2362 / 0.2350	<b>J</b>	in	Ø 0.7480 / 0.7475	Ø 0.8665 / 0.8659
	mm	6 h9	6 h9		mm	19 h6	22 j6
<b>B</b>	in	3.54	3.54	<b>K</b>	in	1.57	1.89
	mm	90	90		mm	40	48
<b>C</b>	in	3.54	3.54	<b>L</b>	in	0.39	0.63
	mm	90	90		mm	10	16
<b>D</b>	in	Ø 3.1492 / 3.1485	Ø 3.1492 / 3.1485	<b>M</b>	in	See Below	See Below
	mm	80 g6	80 g6		mm	See Below	See Below
<b>E</b>	in	0.85	0.96	<b>N</b>	in	2.15	2.15
	mm	21.5	24.5		mm	55	55
<b>F</b>	in	4X Ø 0.28 ON BC	4X Ø 0.257 ON BC	<b>O</b>	in	6.95	6.95
	mm	7	6.5		mm	177	177
<b>G</b>	in	Ø 3.94 BC	Ø 3.94 BC	<b>P</b>	in	1.30	1.30
	mm	100	100		mm	33	33
<b>H</b>	in	0.12	0.118	<b>Q</b>	in	3.74	3.74
	mm	3	3		mm	95	95
<b>I</b>	in	1.38	1.417	<b>R</b>	in	1.25	1.25
	mm	35	36		mm	32	32

### R2M090

Without Brake Option		
<b>DIM</b>	2 Stack Stator	3 Stack Stator
M	10.25 (256.3)	11.25 (285.8)

With Brake Option		
<b>DIM</b>	2 Stack Stator	3 Stack Stator
M	11.6 (294.6)	12.6 (320.0)

### R2G090

Without Brake Option		
<b>DIM</b>	2 Stack Stator 1 Stage Gearhead	3 Stack Stator 1 Stage Gearhead
M	12.36 (313.9)	13.36 (339.3)
<b>DIM</b>	2 Stack Stator 2 Stage Gearhead	3 Stack Stator 2 Stage Gearhead
M	13.63 (346.2)	14.63 (371.6)

With Brake Option		
<b>DIM</b>	2 Stack Stator 1 Stage Gearhead	3 Stack Stator 1 Stage Gearhead
M	13.67 (347.2)	14.67 (372.6)
<b>DIM</b>	2 Stack Stator 2 Stage Gearhead	3 Stack Stator 2 Stage Gearhead
M	14.94 (379.5)	15.94 (404.9)

Pre-sale drawings and models are representative and are subject to change. Certified drawings and models are available for a fee. Consult your local Exlar representative for details.

## R2M/G115 Base Actuator

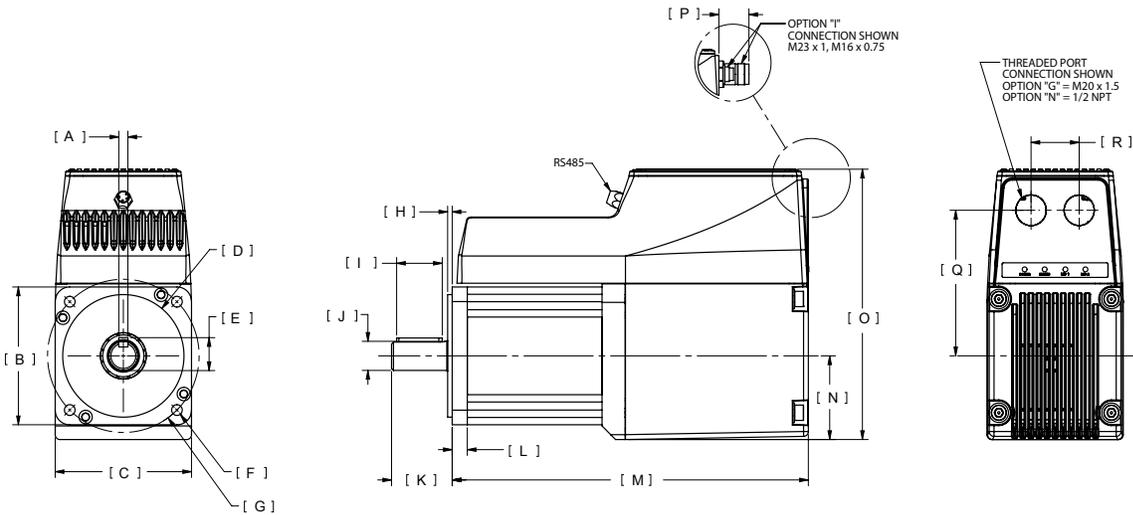

		R2M115	R2G115			R2M115	R2G115
<b>A</b>	in	0.3150 / 0.3135	0.3937 / 0.3923	<b>J</b>	in	Ø 0.9449 / 0.9444	Ø 1.2603 / 1.2596
	mm	8 h9	10 h9		mm	24 h6	32 j6
<b>B</b>	in	4.53	4.530	<b>K</b>	in	1.97	2.55
	mm	115	115		mm	50	65
<b>C</b>	in	4.53	4.530	<b>L</b>	in	0.45	0.64
	mm	115	115		mm	12	16
<b>D</b>	in	Ø 4.3302 / 4.3294	Ø 4.3302 / 4.3294	<b>M</b>	in	See Below	See Below
	mm	110 g6	110 g6		mm	See Below	See Below
<b>E</b>	in	1.06	1.380	<b>N</b>	in	2.27	2.27
	mm	27	35		mm	58	58
<b>F</b>	in	4 X Ø 0.34 ON BC	4 X Ø 0.34 ON BC	<b>O</b>	in	7.56	7.56
	mm	8.5	8.5		mm	192	192
<b>G</b>	in	Ø 5.12 BC	Ø 5.12 BC	<b>P</b>	in	1.30	1.30
	mm	130	130		mm	33	33
<b>H</b>	in	0.16	0.16	<b>Q</b>	in	4.23	4.23
	mm	4	4		mm	108	108
<b>I</b>	in	1.41	1.58	<b>R</b>	in	1.25	1.25
	mm	35.9	40		mm	32	32

### R2M115

Without Brake Option		
DIM	1 Stack Stator	2 Stack Stator
M	9.87 (250.7)	11.87 (301.5)

With Brake Option		
DIM	1 Stack Stator	2 Stack Stator
M	11.60 (294.6)	13.60 (345.4)

### R2G115

Without Brake Option		
DIM	1 Stack Stator 1 Stage Gearhead	2 Stack Stator 1 Stage Gearhead
M	13.88 (352.6)	15.88 (403.4)
DIM	1 Stack Stator 2 Stage Gearhead	2 Stack Stator 2 Stage Gearhead
M	15.49 (393.4)	17.49 (444.2)

With Brake Option		
DIM	1 Stack Stator 1 Stage Gearhead	2 Stack Stator 1 Stage Gearhead
M	15.43 (391.9)	17.43 (442.7)
DIM	1 Stack Stator 2 Stage Gearhead	2 Stack Stator 2 Stage Gearhead
M	17.04 (432.8)	19.04 (483.6)

Pre-sale drawings and models are representative and are subject to change. Certified drawings and models are available for a fee. Consult your local Exlar representative for details.

## Ordering Information

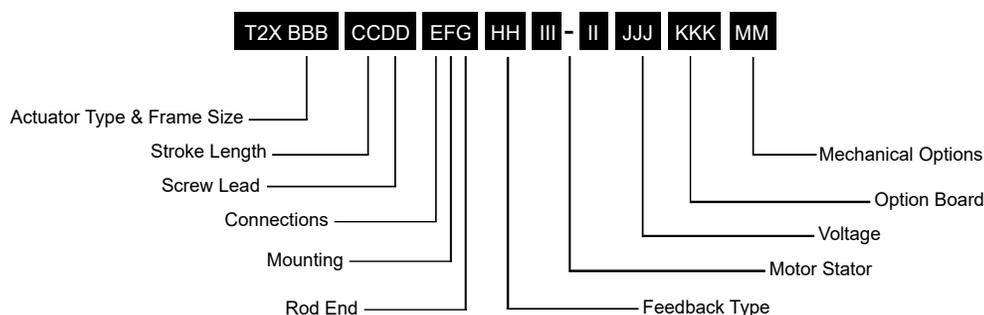

### Actuator Type

T2X = Tritex II Linear Actuator, high mechanical capacity

### BBB = Actuator Frame Size

090 = 90 mm  
115 = 115 mm

### CC = Stroke Length

03 = 3 inch (76 mm) (N/A T2M/X115)  
04 = 4 inch (102 mm) (T2M/X115 only)  
06 = 6 inch (152 mm)  
10 = 10 inch (254 mm)  
12 = 12 inch (305 mm)  
14 = 14 inch (356 mm)  
18 = 18 inch (457 mm)

### DD = Screw Lead (linear travel per screw revolution)

01 = 0.1 inch (2.54 mm)  
02 = 0.2 inch (5.08 mm)  
05 = 0.5 inch (12.7 mm)  
08 = 0.75 inch (19.05 mm) (T2M/X115 only)<sup>2</sup>

### E = Connections

G = Standard Straight Threaded Port with Internal terminals, M20 x 1.5  
N = NPT Threaded Port via Adapter with Internal Terminals, 1/2" NPT  
I = Intercontec Style - Exlar std, M16/M23 Style Connector

### F = Mounting

C = Rear Clevis  
D = Double Side Mount  
E = Extended Tie Rod  
F = Front Flange  
G = Metric Rear Clevis  
K = Metric Double Side Mount  
M = Metric Extended Tie Rod  
Q = Metric Side Trunnion  
R = Rear Flange  
T = Side Trunnion

### G = Rod End

A = Male Metric Thread<sup>1</sup>  
B = Female Metric Thread<sup>1</sup>  
F = Female US Standard Thread<sup>1</sup>  
M = Male US Standard Thread<sup>1</sup>

### HH = Feedback Type

HD = Analog Hall Device  
IE = Incremental Encoder, 8192 count resolution  
AF = Absolute Feedback

### III-II = Motor Stator, All 8 Pole

T2X090 Stator Specifications  
138-40 = 1 Stack, 230 VAC, 4000 rpm  
238-40 = 2 Stack, 230 VAC, 4000 rpm  
238-30 = 2 Stack, 230 VAC, 3000 rpm<sup>6</sup>

### T2X115 Stator Specifications

138-30 = 1 Stack, 230 VAC, 3000 rpm  
238-20 = 2 Stack, 230 VAC, 2000 rpm<sup>8</sup>  
238-15 = 2 Stack, 230 VAC, 1500 rpm<sup>6,8</sup>  
(N/A with 0.1" lead)

### JJJ = Voltage

230 = 115-230 VAC, single phase

### KKK = Option Board

SIO = Standard I/O Interconnect  
IA4 = 4-20 mA Analog I/O  
EIP = SIO plus Ethernet/IP w/M12 connector  
EIN = SIO plus Ethernet/IP without M12 connector<sup>7</sup>  
PIO = SIO plus Profinet IO w/M12 connector  
PIN = SIO plus Profinet IO without M12 connector<sup>7</sup>  
TCP = SIO plus Modbus TCP w/M12 connector  
TCN = SIO plus Modbus TCP without M12 connector<sup>10</sup>

### MM = Mechanical Options<sup>3</sup>

AR = External Anti-rotate  
L1/2/3 = External Limit Switches<sup>4</sup>  
RB = Rear Brake  
PB = Protective Bellows (N/A with extended tie rod mounting option)  
SR = Splined Main Rod<sup>5</sup>



For options or specials not listed above or for extended temperature operation, please contact Exlar

#### NOTES:

1. Chrome-plated carbon steel. Threads not chrome-plated.
2. 0.75 lead not available above 12 inch stroke.
3. For extended temperature operation consult factory for model number.

4. Limit switch option requires AR option.
5. This option is not sealed and is not suitable for any environment in which contaminants come in contact with actuator and may enter the actuator.

6. N/A with 0.1 inch lead
7. Requires customer supplied Ethernet cable through I/O port for Class 1 Division 2 compliance only.
8. Not available with 4 inch stroke.

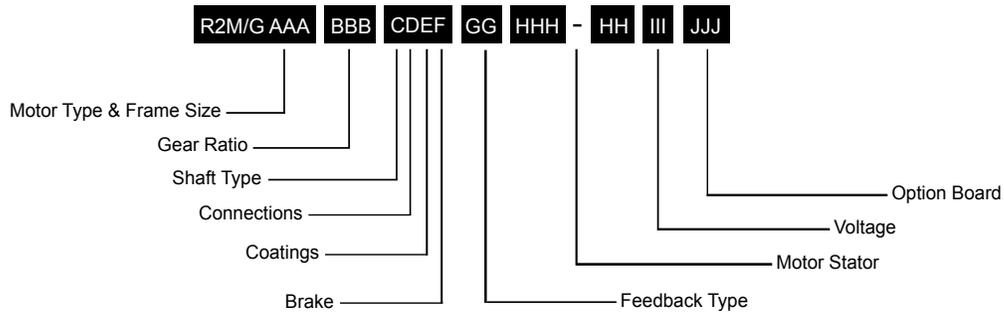

### R2M/G = Motor Type

R2M = Tritex II AC Rotary Motor  
R2G = Tritex II AC Rotary Gearmotor

### AAA = Frame Size

075 = 75 mm  
090 = 90 mm  
115 = 115 mm

### BBB = Gear Ratio

Blank = R2M  
Single Reduction Ratios  
004 = 4:1  
005 = 5:1  
010 = 10:1  
Double Reduction Ratios (N/A on 75 mm)  
016 = 16:1    020 = 20:1  
025 = 25:1    040 = 40:1  
050 = 50:1    100 = 100:1

### C = Shaft Type

K = Keyed

### D = Connections

G = Standard Straight Threaded Port with Internal Terminals, M20 x 1.5  
N = NPT Threaded Port with Internal Terminals, 1/2" NPT  
I = Intercontec style - Exlar Standard, M16/M23 Style Connector

### E = Coating Options

G = Exlar Standard

### F = Brake Option

S = No Brake, Standard  
B = Electric Brake, 24 VDC

### GG = Feedback Type

HD = Analog Hall Device  
IE = Incremental Encoder, 8192 Count Resolution  
AF = Absolute Feedback

### HHH-HH = Motor Stators

R2M/G075 Stator Specifications  
138-40 = 1 Stack, 230 VAC, 4000 rpm  
238-30 = 2 Stack, 230 VAC, 3000 rpm  
338-20 = 3 Stack, 230 VAC, 2000 rpm

R2M/G090 Stator Specifications  
238-40 = 2 Stack, 230 VAC, 4000 rpm  
238-30 = 2 Stack, 230 VAC, 3000 rpm  
338-20 = 3 Stack, 230 VAC, 2000 rpm

R2M/G115 Stator Specifications  
138-30 = 1 Stack, 230 VAC, 3000 rpm  
238-20 = 2 Stack, 230 VAC, 2000 rpm  
238-15 = 2 Stack, 230 VAC, 1500 rpm

### III = Voltage

230 = 115-230 VAC, Single Phase

### JJJ = Option Board

SIO = Standard I/O Interconnect  
IA4 = 4-20 mA Analog I/O  
EIP = SIO plus Ethernet/IP w/M12 connector  
EIN = SIO plus Ethernet/IP without M12 connector<sup>1</sup>  
PIO = SIO plus Profinet IO w/M12 connector  
PIN = SIO plus Profinet IO without M12 connector<sup>1</sup>  
TCP = SIO plus Modbus TCP w/M12 connector  
TCN = SIO plus Modbus TCP without M12 connector<sup>1</sup>



For options or specials not listed above or for extended temperature operation, please contact Exlar

#### NOTES:

- Requires customer supplied Ethernet cable through I/O port for Class 1 Division 2 compliance only.
- For extended temperature operation consult factory for model number.

## Cable and Accessories

Tritex II AC Series Cable & Accessories	Part No.
<b>Communications Accessories - Tritex uses a 4 pin M8 RS485 communications connector</b>	
Recommended PC to Tritex communications cable-USB/RS485 to M8 connector - xxx = Length in feet, 006 or 015 only	CBL-T2USB485-M8-xxx
<b>Multi-Drop RS485 Accessories</b>	
RS485 splitter - M8 Pin plug to double M8 Socket receptacle	TT485SP
Multidrop Communications Cable M8 to M8 for use with TT485SP/RS485 splitter - xxx = Length in feet, 006 or 015 only	CBL-TTDAS-xxx
<b>"G" Connection Accessories</b>	
Nickel plated cable gland- M20 x 1.5 - CE shielding- 2 required	GLD-T2M20 x 1.5
Power cable prepared on one end for use with GLD-T2M20 x 1.5 xxx = Length in ft, Standard lengths 015, 025, 050, 075, 100	CBL-T2IPC-RAW-xxx
I/O cable prepared on one end for use with GLD-T2M20 x 1.5 xxx = Length in ft, Standard lengths 015, 025, 050, 075, 100	CBL-T2IOC-RAW-xxx
<b>"N" Connection Accessories</b>	
M20 x 1.5 to 1/2" NPT threaded hole adapter for use with conduit	ADAPT-M20-NPT1/2
<b>"I" Connection</b>	
Power cable with M23 6 pin xxx = Length in feet, std lengths 015, 025, 050, 075, 100	CBL-T2IPC-SMI-xxx
I/O cable (90 & 115 mm) with M16 19 pin xxx = Length in feet, std lengths 015, 025, 050, 075, 100	CBL-T2IOC-SMI-xxx
<b>Multi-Purpose Communications Accessories for long runs, requires terminal block interconnections</b>	
USB to RS485 convertor/cable - USB to RS485 flying leads - xxx = Length in feet, 006 or 015 only	CBL-T2USB485-xxx
Communications cable M8 to flying leads cable xxx = Length in feet, standard lengths 015, 025, 050, 075, 100	CBL-TTCOM-xxx
<b>Option Board Cables and Accessories</b>	
EIP, PIO and TCP option Ethernet cable - M12 to RJ45 cable xxx = Length in feet, std lengths 015, 025, 050, 075, 100.	CBL-T2ETH-R45-xxx
<b>Electrical Accessories</b>	
Dynamic Braking Resistor - 100W470hm	T2BR1
Replacement -AF Battery - used for absolute feedback option	T2BAT1
Replacement Normally Closed External Limit Switch (Turck Part number BIM-UNT-RP6X)	43404
Replacement Normally Open External Limit Switch (Turck Part number BIM-UNT-AP6X)	43403
<b>Mechanical Accessories</b>	
Clevis Pin for T2X090 male "M" rod end 1/2-20 thread	CP050
Clevis Pin for T2X115 male "M" rod end 3/4-16 thread	CP075
Spherical Rod Eye for T2X090 male "M" rod end 1/2-20 thread	SRM050
Spherical Rod Eye for T2X115 male "M" rod end 3/4-16 thread	SRM075
Rod Eye for T2X090 male "M" rod end 1/2-20 thread	REI050
Rod Eye for T2X115 male "M" rod end 3/4-16 thread	RE075
Rod Clevis for T2X090 male "M" rod end 1/2-20 thread	RCI050
Rod Clevis for T2X115 male "M" rod end 3/4-16 thread	RC075
Jam Nut for T2X090 male rod end, 1/2 - 20	JAM1/2-20-SS
Jam Nut for T2X115 male rod end, 3/4-16	JAM3/4-16-SS



CBL-T2USB485-M8-xxx  
Our recommended communications cable. No special drivers or setup required for use with MS Windows™.



CBL-T2USB485-xxx  
Use for terminal connections with CBL-TTCOM for long cable runs. No special drivers or setup required for use with MS Windows™.



CBL-TTIOC-SMI-xxx



CBL-TTIPC-SMI-xxx



CBL-TTETH-R45-xxx  
Use with CBL-T2USB485-xxx for long cable runs.



CBL-TTDAS-xxx  
For use with TT485SP for multi-drop applications.



TT485SP  
RS485 communications splitter. Use to daisy-chain multiple Tritex actuators.

## Tritex II DC

### Linear & Rotary Actuators

No Compromising on Power, Performance or Reliability  
 With forces to approximately 950 lbs (4kN) continuous and 1,300 lbf peak (6 kN), and speeds to 33 in/sec (800 mm/sec), the DC Tritex II linear actuators also offer a benefit that no other integrated product offers: POWER! No longer are you limited to trivial amounts of force, or speeds so slow that many motion applications are not possible. And the new Tritex II with DC power electronics operates with maximum reliability over a broad range of ambient temperatures: -40°C to +65°C. The DC powered Tritex II actuators contain a 750 W servo amplifier and a very capable motion controller. With standard features such as analog following for position, compound moves, move chaining, and individual force/torque control for each move, the Tritex II Series is the ideal solution for most motion applications.

#### Tritex II Models

- RDM rotary motor, 60, 75, and 90 mm
- RDG rotary gearmotor, 60, 75, and 90 mm

#### Power Requirements

- DC Power 12-48 VDC nominal
- Connections for external braking resistor

#### Feedback Types

- Analog Hall with 1000 count resolution
- Incremental encoder with 8192 count resolution
- Absolute Feedback (analog hall with multi-turn, battery backup)

#### Connectivity

- Internal terminals accessible through removable cover (75 and 90 mm models)
- Threaded ports for cable glands (75 and 90 mm models)
- Optional connectors - M23 Power - M23 I/O
- M8 connector for RS485
- M12 connector for EtherNet options
- Custom connection options
- Embedded leads

Technical Characteristics	
Frame Sizes in (mm)	2.3 (60), 2.9 (75)
Screw Leads in (mm)	0.1 (2), 0.2 (5), 0.4 (10), 0.5 (13)
Standard Stroke Lengths in (mm)	3 (76), 6 (152), 10 (254), 12 (305), 14 (356), 18 (457)
Force Range	up to 872 lbf (3879 N)
Maximum Speed	up to 33.3 in/s (846 mm/s)

Tritex II Linear DC Actuator



Tritex II Rotary Motor with Connectors



Tritex II Linear Actuator with Customer-supplied Cable Glands Ports

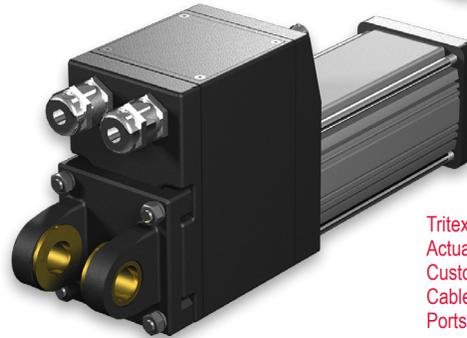

#### Operating Conditions and Usage

<b>Accuracy:</b>		
Screw Lead Error	in/ft ( $\mu\text{m}$ / 300 mm)	0.001 (25)
Screw Travel Variation	in/ft ( $\mu\text{m}$ / 300 mm)	0.0012 (30)
Screw Lead Backlash	in	0.004 (TDX),
<b>Ambient Conditions:</b>		
Standard Ambient Temperature	°C	0 to 65
Extended Ambient Temperature**	°C	-40 to 65
Storage Temperature	°C	-40 to 85
IP Rating		RDM/RDG = IP66S
NEMA Ratings		None
Vibration		5.0 g rms, 5 to 500 hz

\*Ratings at 40°C, operation over 40°C requires de-rating.

\*\*Consult Exlar for extended temperature operation.

## Communications & I/O

### Digital Inputs:

9 to 30 VDC Opto-isolated

### Digital Outputs:

30 VDC maximum

100 mA continuous output

Isolated

Short circuit and over temperature protected

### Analog Input DC:

0-10V or +/-10V

0-10V mode, 12 bit resolution

+/-10V mode, 13 bit resolution assignable to Position, Velocity, Torque, or Velocity override command

### Analog Output DC:

0-10V

11 bit resolution

### IA4 option:

4-20 mA input

16 bit resolution

Isolated

Assignable to Position, Velocity, Torque, or Velocity Override command

4-20 mA output

12 bit resolution

Assignable to Position, Velocity, Current, Temperature, etc.

### Standard Communications:

- 1 RS485 port, Modbus RTU, opto-isolated for programming, controlling and monitoring

Tritex II DC I/O		
	60/75/90 mm frame with SIO, EIP, PIO, TCP	60/75/90 mm frame with IA4
Isolated digital inputs	8	4
Isolated digital outputs	4	3
Analog input, non isolated	1	0
Analog output, non isolated	1	0
Isolated 4-20ma input	0	1
Isolated 4-20ma output	0	1

The IO count and type vary with the actuator model and option module selected.

All models include isolated digital IO, and an isolated RS485 communication port when using Modbus RTU protocol.

## Product Features

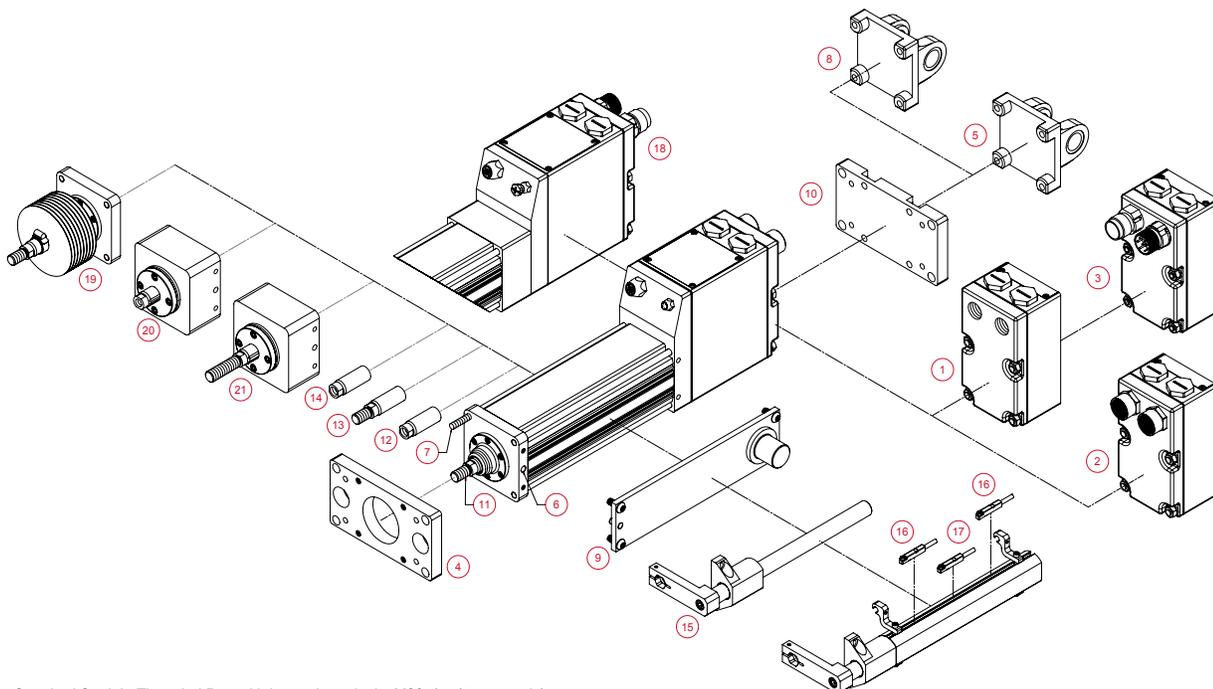
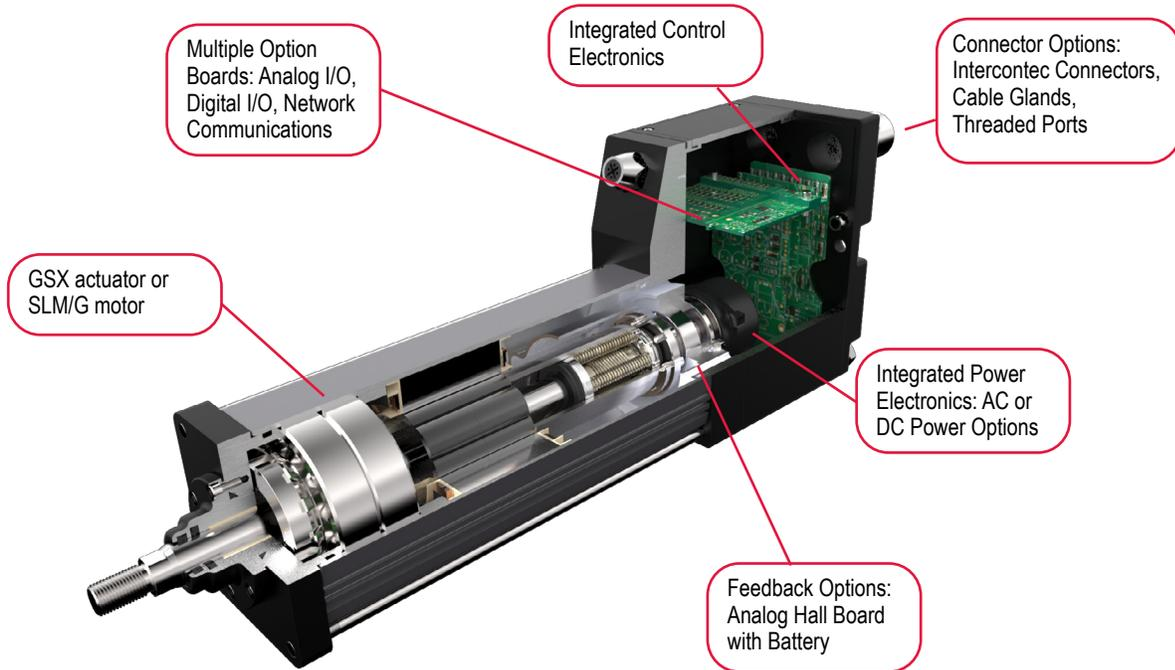

- 1 - Standard Straight Threaded Port with internal terminals, M20x1.5 (75 mm only)
- 2 - NPT Threaded Port via Adapter with Internal Terminals, 1/2" NPT (75 mm only)
- 3 - Interconnect Style - Exlar standard, M23 Style Connector
- 4 - Front Flange
- 5 - Rear Clevis
- 6 - Double Side Mount and Metric Double Side Mount
- 7 - Extended Tie Rod and Metric Extended Tie Rod
- 8 - Metric Rear Clevis
- 9 - Metric Side Trunnion and Side Trunnion
- 10 - Female Metric Thread
- 11 - Male Metric Thread
- 12 - Female Metric Thread
- 13 - Male US Standard Thread
- 14 - Female US Standard Thread
- 15 - External Anti-rotate
- 16 - External Limit Switch - N.C., PNP
- 17 - External Limit Switch - N.O., PNP
- 18 - Rear Brake
- 19 - Protective Bellows
- 20 - Splined Main Rod - Female
- 21 - Splined Main Rod - Male

## Industries and Applications

Hydraulic cylinder replacement  
 Ball screw replacement  
 Pneumatic cylinder replacement

### Mobile Equipment

Unmanned Vehicles

### Process Control

Oil & Gas Wellhead Valve Control  
 Pipeline Valve Control  
 Damper Control  
 Knife Valve Control  
 Chemical pumps

### Entertainment / Simulation

Ride Motion Bases  
 Animatronics

Since no fluids and associated equipment (pumps, compressors, filters, accumulators, hose/tubing, oil testing, etc.) are required, electromechanical actuators offer greater energy efficiency, less environmental impact and lower total life-cycle cost.

The Tritex II Series DC actuators integrate a DC powered servo drive, digital position controller, brushless motor, and linear actuator in a compact, sealed package making it perfect for environments where AC power is difficult to achieve.

## Options

### AR = External Anti-rotate Assembly

This option provides a rod and bushing to restrict the actuator rod from rotating when the load is not held by another method. Shorter actuators have single sided anti-rotation attachments. Longer lengths require attachments on both sides for proper operation. For AR dimensions, see page 79.

### L1, L2, L3 = Adjustable External Travel Switches

This option allows up to 3 external switches to be included. These switches provide travel indication to the controller and are adjustable. See drawing on page 29. Must purchase external anti-rotate with this option.

### RB = Rear Electric Brake

This option provides an internal holding brake. The brake is spring activated and electrically released.

### PB = Protective Bellows

This option provides an accordion style protective bellows to protect the main actuator rod from damage due to abrasives or other contaminants in the environment in which the actuator must survive. The standard material of this bellows is S2 Neoprene Coated Nylon, Sewn Construction. This standard bellows is rated for environmental temperatures of -40 to 250 degrees F. Longer strokes may require the main rod of the actuator to be extended beyond standard length. Not available with extended tie rod mounting option. Please contact your local sales representative.

### SR = Splined Main Rod

A ball spline shafting main rod with a ball spline nut that replaces the standard front seal and bushing assembly. This rod restricts rotation without the need for an external mechanism. The rod diameter will be the closest metric equivalent to our standard rod sizes. Since this option is NOT sealed, it is not suitable for environments in which contaminants may enter the actuator.

Note: Adding this option affects the overall length and mounting dimensions.

## Mechanical Specifications

### RDM/G060

Rotary Motor Torque and Speed Ratings				
	Stator	1 Stack	2 Stack	3 Stack
	RPM at 48 VDC	5000	5000	4000
Continuous Torque	lbf-in (Nm)	6.8 (0.76)	10.5 (1.18)	13 (1.47)
Peak Torque	lbf-in (Nm)	12.8 (1.44)	13.3 (1.5)	17 (1.92)
Drive Current @ Continuous Torque	Amps	14.8	21.5	21.5
Operating Temperature Range**	-20 to 65° C (-40° C available, consult Exlar)			
Maximum Continuous Power Supply Current†	Amps	8	11	13

\*Power supply current is based on software current limit, not thermal limit. Consideration for peak current should also be considered when sizing power supplies. For output torque of RDG gearmotors, multiply by ratio and efficiency. Please note maximum allowable output torques found at bottom of page.

\*\*Ratings based on 40° C ambient conditions.

Inertia				
	Stator	1 Stack	2 Stack	3 Stack
RDM Motor Armature Inertia (+/-5%)	lbf-in-sec <sup>2</sup> (kg-cm <sup>2</sup> )	0.000237 (0.268)	0.000413 (0.466)	0.000589 (0.665)
RDG Gearmotor Armature Inertia†	lbf-in-sec <sup>2</sup> (kg-cm <sup>2</sup> )	0.000226 (0.255)	0.000401 (0.453)	0.000576 (0.651)

\*Add armature inertia to gearing inertia for total inertia.

L <sub>10</sub> Radial Load and Bearing Life						
RPM	50	100	250	500	1000	3000
RDM060 lbf (N)	250 (1112)	198 (881)	148 (658)	116 (516)	92 (409)	64 (285)
RDG060 lbf (N)	189 (841)	150 (667)	110 (489)	88 (391)	70 (311)	48 (214)

Side load ratings shown above are for 10,000 hour bearing life at 25 mm from motor face at given rpm.

Gearmotor Mechanical Ratings					
Model	Ratio	Maximum Allowable Output Torque-Set by User lbf-in (Nm)	Output Torque at Motor Speed for 10,000 Hour Life		
			1000 RPM lbf-in (Nm)	3000 RPM lbf-in (Nm)	5000 RPM lbf-in (Nm)
RDG060-004	4:1	603 (68.1)	144 (16.2)	104 (11.7)	88 (9.9)
RDG060-005	5:1	522 (58.9)	170 (19.2)	125 (14.1)	105 (11.9)
RDG060-010	10:1	327 (36.9)	200 (22.6)	140 (15.8)	120 (13.6)
RDG060-016	16:1	603 (68.1)	224 (25.3)	160 (18.1)	136 (15.4)
RDG060-020	20:1	603 (68.1)	240 (27.1)	170 (19.2)	146 (16.5)
RDG060-025	25:1	522 (58.9)	275 (31.1)	200 (22.6)	180 (20.3)
RDG060-040	40:1	603 (68.1)	288 (32.5)	208 (23.5)	180 (20.3)
RDG060-050	50:1	522 (58.9)	340 (38.4)	245 (27.7)	210 (23.7)
RDG060-100	100:1	327 (36.9)	320 (36.1)	280 (31.6)	240 (27.1)

Two torque ratings for the RDG gearmotors are given in the table above. The left hand columns give the maximum (peak) allowable output torque for the indicated ratios of each size RDG gearmotor. This is not the rated output torque of the motor multiplied by the ratio of the reducer.

It is possible to select a configuration of the motor selection and gear ratio such that the rated motor torque, multiplied by the gear ratio exceeds these ratings. It is the responsibility of the user to ensure that the settings of the system do not allow these values to be exceeded.

The right hand columns give the output torque at the indicated speed which will result in 10,000 hour life (L10). The setup of the system will determine the actual output torque and speed.

Gearing Reflected Inertia					
Single Reduction			Double Reduction		
Gear Stages	lbf-in-sec <sup>2</sup>	(kg-cm <sup>2</sup> )	Gear Stages	lbf-in-sec <sup>2</sup>	(kg-cm <sup>2</sup> )
4:1	0.0000132	(0.149)	16:1	0.0000121	(0.0137)
5:1	0.0000087	(0.00984)	20:1, 25:1	0.0000080	(0.00906)
10:1	0.0000023	(0.00261)	40:1, 50:1, 100:1	0.0000021	(0.00242)

Backlash and Efficiency		
	Single Reduction	Double Reduction
Backlash at 1% Rated Torque	10 Arc min	13 Arc min
Efficiency	91%	86%

Motor and Gearmotor Weights				
	RDM060 without Gears	RDG060 with 1 Stage Gearing	RDG060 with 2 Stage Gearing	Added Weight for Brake
1 Stack Stator	lb (kg)	3.0 (1.4)	7.5 (3.4)	9.3 (4.2)
2 Stack Stator	lb (kg)	4.1 (1.9)	8.6 (3.9)	10.4 (4.7)
3 Stack Stator	lb (kg)	5.2 (2.4)	9.7 (4.4)	11.5 (5.2)

0.6 (0.3)

**RDM/G075**

<b>Rotary Motor Torque and Speed Ratings</b>				
	Stator	1 Stack	2 Stack	3 Stack
	RPM at 48 VDC	4000	3000	2000
Continuous Torque	lbf-in (Nm)	13 (1.46)	18.5 (2.09)	29 (3.28)
Peak Torque	lbf-in (Nm)	18.9 (2.08)	28 (3.16)	41 (4.63)
Drive Current @ Continuous Torque	Amps	22	22	22
Operating Temperature Range**	-20 to 65° C (-40° C available, consult Exlar)			
Maximum Continuous Power Supply Current†	Amps	15	18	18

\*Power supply current is based on software current limit, not thermal limit. Consideration for peak current should also be considered when sizing power supplies. For output torque of RDG gearmotors, multiply by ratio and efficiency. Please note maximum allowable output torques shown below.

\*\*Ratings based on 40° C ambient conditions.

<b>Inertia</b>				
	Stator	1 Stack	2 Stack	3 Stack
RDM Motor Armature Inertia (+/-5%)	lb-in-sec <sup>2</sup> (kg-cm <sup>2</sup> )	0.000545 (0.6158)	0.000973 (1.0996)	0.001401 (1.5834)
RDG Gearmotor Armature Inertia† (+/-5%)	lb-in-sec <sup>2</sup> (kg-cm <sup>2</sup> )	0.000660 (0.7450)	0.001068 (1.2057)	0.001494 (1.6868)

\*Add armature inertia to gearing inertia for total inertia.

<b>L<sub>10</sub> Radial Load and Bearing Life</b>						
RPM	50	100	250	500	1000	3000
RDM075 lbf (N)	278 (1237)	220 (979)	162 (721)	129 (574)	102 (454)	71 (316)
RDG075 lbf (N)	343 (1526)	272 (1210)	200 (890)	159 (707)	126 (560)	88 (391)

Side load ratings shown above are for 10,000 hour bearing life at 25 mm from motor face at given rpm.

<b>Gearmotor Mechanical Ratings</b>					
Model	Ratio	Maximum Allowable Output Torque-Set by User lbf-in (Nm)	Output Torque at Motor Speed for 10,000 Hour Life		
			1000 RPM lbf-in (Nm)	2500 RPM lbf-in (Nm)	4000 RPM lbf-in (Nm)
RDG075-004	4:1	1618 (182.8)	384 (43.4)	292 (32.9)	254 (28.7)
RDG075-005	5:1	1446 (163.4)	395 (44.6)	300 (33.9)	260 (29.4)
RDG075-010	10:1	700 (79.1)	449 (50.7)	341 (38.5)	296 (33.4)

Two torque ratings for the RDG gearmotors are given in the table above. The left hand columns give the maximum (peak) allowable output torque for the indicated ratios of each size RDG gearmotor. This is not the rated output torque of the motor multiplied by the ratio of the reducer. It is possible to select a configuration of the motor selection and gear ratio such that the rated motor torque, multiplied by the gear ratio exceeds these ratings. It is the responsibility of the user to ensure that the settings of the system do not allow these values to be exceeded.

The right hand columns give the output torque at the indicated speed which will result in 10,000 hour life (L10). The setup of the system will determine the actual output torque and speed.

<b>Gearing Reflected Inertia</b>		
Single Reduction (+/-5%)		
Gear Stages	lbf-in-sec <sup>2</sup>	(kg-cm <sup>2</sup> )
4:1	0.000095	(0.107)
5:1	0.000062	(0.069)
10:1	0.000117	(0.019)

<b>Backlash and Efficiency</b>	
	Single Reduction
Backlash at 1% Rated Torque	10 Arc min
Efficiency	91%

<b>Motor and Gearmotor Weights</b>				
		RDM075 without Gears	RDG075 with 1 Stage Gearing	Added Weight for Brake
1 Stack Stator	lb (kg)	7.4 (3.4)	9.8 (4.4)	1.0 (0.5)
2 Stack Stator	lb (kg)	9.2 (4.2)	11.6 (5.3)	
3 Stack Stator	lb (kg)	11 (4.9)	13.4 (6.1)	

## RDM/G090

Rotary Motor Torque and Speed Ratings				
	Stator	1 Stack	2 Stack	3 Stack
	RPM at 48 VDC	3300	1800	1400
Continuous Torque	lbf-in (Nm)	17 (1.92)	28 (3.16)	41 (4.63)
Peak Torque	lbf-in (Nm)	21.8 (2.46)	36 (4.07)	52.8 (5.97)
Drive Current @ Continuous Torque	Amps	22	22	22
Operating Temperature Range**	-20 to 65° C (-40° C available, consult Exlar)			
Maximum Continuous Power Supply Current†	Amps	18	18	18

\*Power supply current is based on software current limit, not thermal limit. Consideration for peak current should also be considered when sizing power supplies. For output torque of RDG gearmotors, multiply by ratio and efficiency. Please note maximum allowable output torques shown below.

\*\*Ratings based on 40° C ambient conditions.

Inertia				
	Stator	1 Stack	2 Stack	3 Stack
RDM Motor Armature Inertia (+/-5%)	lb-in-sec <sup>2</sup> (kg-cm <sup>2</sup> )	0.00054 (0.609)	0.00097 (1.09)	0.00140 (1.58)
RDG Gearmotor Armature Inertia† (+/-5%)	lb-in-sec <sup>2</sup> (kg-cm <sup>2</sup> )	0.00114 (1.29)	0.00157 (1.77)	0.00200 (2.26)

†Add armature inertia to gearing inertia for total inertia.

L <sub>10</sub> Radial Load and Bearing Life						
RPM	50	100	250	500	1000	3000
RDM090 lbf (N)	427 (1899)	340 (1512)	250 (1112)	198 (881)	158 (703)	109 (485)
RDG090 lbf (N)	350 (1557)	278 (1237)	205 (912)	163 (725)	129 (574)	89 (396)

Side load ratings shown above are for 10,000 hour bearing life at 25 mm from motor face at given rpm.

Gearmotor Mechanical Ratings					
Model	Ratio	Maximum Allowable Output Torque-Set by User lbf-in (Nm)	Output Torque at Motor Speed for 10,000 Hour Life		
			1000 RPM lbf-in (Nm)	2500 RPM lbf-in (Nm)	3300 RPM lbf-in (Nm)
RDG090-004	4:1	2078 (234.8)	698 (78.9)	530 (59.9)	488 (55.1)
RDG090-005	5:1	1798 (203.1)	896 (101.2)	680 (76.8)	626 (70.7)
RDG090-010	10:1	1126 (127.2)	1043 (117.8)	792 (89.5)	729 (82.4)
RDG090-016	16:1	2078 (234.8)	1057 (119.4)	803 (90.7)	739 (83.5)
RDG090-020	20:1	2078 (234.8)	1131 (127.8)	859 (97.1)	790 (89.3)
RDG090-025	25:1	1798 (203.1)	1452 (164.1)	1103 (124.6)	1015 (114.7)
RDG090-040	40:1	2078 (234.8)	1392 (157.3)	1057 (119.4)	973 (109.9)
RDG090-050	50:1	1798 (203.1)	1787 (201.9)	1358 (153.4)	1249 (141.1)
RDG090-100	100:1	1126 (127.2)	1100 (124.3)	1100 (124.3)	1100 (124.3)

Two torque ratings for the RDG gearmotors are given in the table above. The left hand columns give the maximum (peak) allowable output torque for the indicated ratios of each size RDG gearmotor. This is not the rated output torque of the motor multiplied by the ratio of the reducer.

It is possible to select a configuration of the motor selection and gear ratio such that the rated motor torque, multiplied by the gear ratio exceeds these ratings. It is the responsibility of the user to ensure that the settings of the system do not allow these values to be exceeded.

The right hand columns give the output torque at the indicated speed which will result in 10,000 hour life (L10). The setup of the system will determine the actual output torque and speed.

Gearing Reflected Inertia					
Single Reduction			Double Reduction		
Gear Stages	lbf-in-sec <sup>2</sup>	(kg-cm <sup>2</sup> )	Gear Stages	lbf-in-sec <sup>2</sup>	(kg-cm <sup>2</sup> )
4:1	0.0000154	(0.174)	16:1	0.000115	(0.130)
5:1	0.0000100	(0.113)	20:1, 25:1	0.0000756	(0.0854)
10:1	0.0000265	(0.0300)	40:1, 50:1, 100:1	0.0000203	(0.0230)

Backlash and Efficiency		
	Single Reduction	Double Reduction
Backlash at 1% Rated Torque	10 Arc min	13 Arc min
Efficiency	91%	86%

Motor and Gearmotor Weights				
	RDM090 without Gears	RDG090 with 1 Stage Gearing	RDG090 with 2 Stage Gearing	Added Weight for Brake
1 Stack Stator lb (kg)	12.5 (5.7)	20.5 (9.3)	23.5 (10.7)	1.5 (0.7)
2 Stack Stator lb (kg)	15.5 (7.0)	23.5 (10.7)	26.5 (12)	
3 Stack Stator lb (kg)	18.5 (8.4)	26.5 (12.0)	29.5 (13.4)	

# Speed vs. Torque Curves

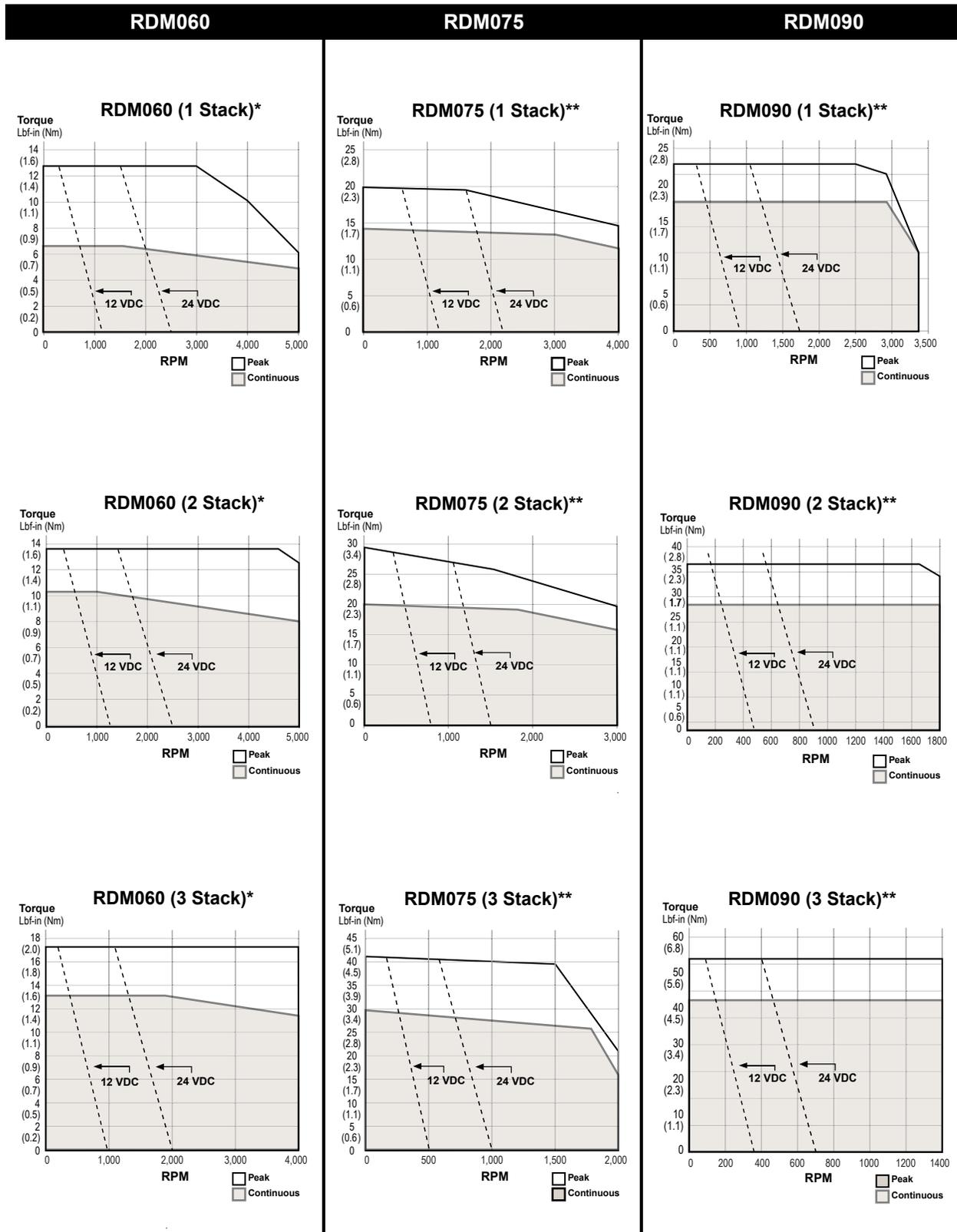

For RDG gearmotors, multiply torque by ratio and efficiency. Divide speed by gear ratio.

\* RDM060 test data derived using NEMA recommended aluminum heatsink 10" x 10" x 1/4" at 40°C ambient

\*\*RDM075 and RDM090 test data derived using NEMA recommended aluminum heatsink 10" x 10" x 3/8" at 40°C ambient

## Dimensions

### RDM/G060 Base Actuator

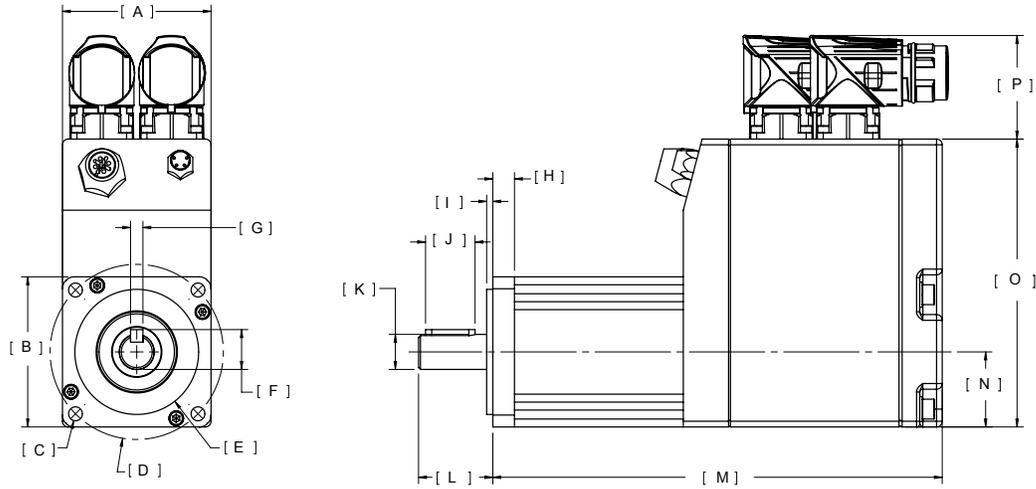

		RDM060	RDG060			RDM060	RDG060
<b>A</b>	in	2.36	2.36	<b>I</b>	in	0.10	0.12
	mm	60	60		mm	2.5	3.0
<b>B</b>	in	2.36	2.36	<b>J</b>	in	0.79	0.98
	mm	60	60		mm	20.0	25.0
<b>C</b>	in	4X Ø 0.22	4X Ø 0.22	<b>K</b>	in	Ø 0.5512 / 0.5507	Ø 0.6302 / 0.6298
	mm	5.6	5.6		mm	14 h6	16 j6
<b>D</b>	in	Ø 2.75 BC	Ø 2.75 BC	<b>L</b>	in	1.18	1.43
	mm	70.0	70.0		mm	30.0	36.3
<b>E</b>	in	Ø 1.9681 / 1.9675	Ø 1.9681 / 1.9675	<b>M</b>	in	See Below	See Below
	mm	50 g6	50 g6		mm	See Below	See Below
<b>F</b>	in	0.63	0.70	<b>N</b>	in	1.18	1.18
	mm	15.9	17.9		mm	30.0	30.0
<b>G</b>	in	Ø 0.1969 / 0.1957	Ø 0.1969 / 0.1957	<b>O</b>	in	4.53	4.53
	mm	5 h9	5 h9		mm	115.1	115.1
<b>H</b>	in	0.34	0.38	<b>P</b>	in	1.63	1.63
	mm	8.7	9.7		mm	41.4	41.4

### RDM060

Without Brake Option			
DIM	1 Stack Stator	2 Stack Stator	3 Stack Stator
M	7.146 (185.1)	8.396 (213.3)	9.646 (245.0)

With Brake Option			
DIM	1 Stack Stator	2 Stack Stator	3 Stack Stator
M	7.856 (199.5)	9.106 (231.3)	10.356 (263.0)

### RDG060

Without Brake Option			
DIM	1 Stack Stator 1 Stage Gearhead	2 Stack Stator 1 Stage Gearhead	3 Stack Stator 1 Stage Gearhead
M	9.434 (240)	10.684 (271)	11.934 (303)
DIM	1 Stack Stator 2 Stage Gearhead	2 Stack Stator 2 Stage Gearhead	3 Stack Stator 2 Stage Gearhead
M	10.479 (266)	11.729 (298)	12.979 (330)

With Brake Option			
DIM	1 Stack Stator 1 Stage Gearhead	2 Stack Stator 1 Stage Gearhead	3 Stack Stator 1 Stage Gearhead
M	10.144 (258)	11.394 (289)	12.644 (321)
DIM	1 Stack Stator 2 Stage Gearhead	2 Stack Stator 2 Stage Gearhead	3 Stack Stator 2 Stage Gearhead
M	11.189 (284)	12.439 (316)	13.689 (348)

Pre-sale drawings and models are representative and are subject to change. Certified drawings and models are available for a fee. Consult your local Exlar representative for details.

### RDM/G075 Base Actuator

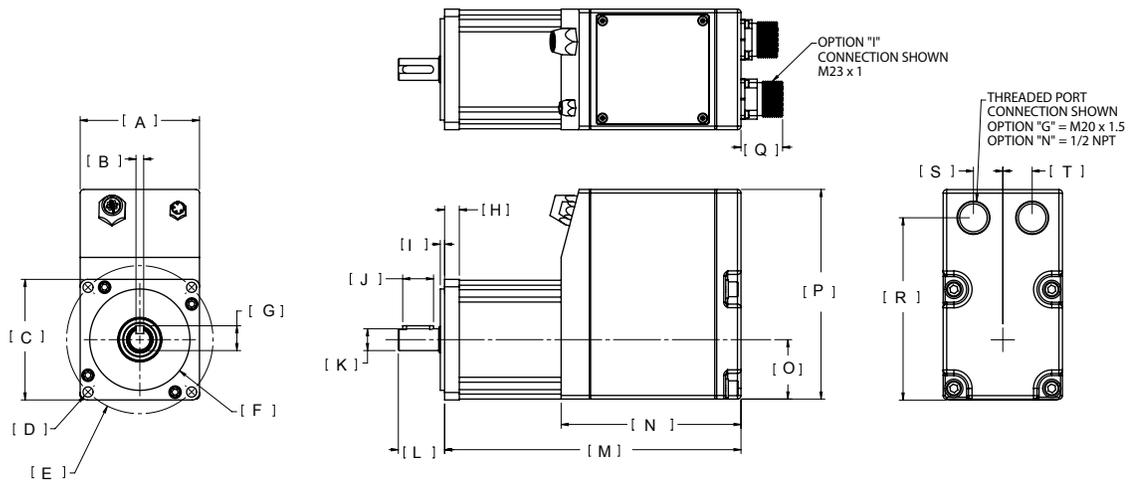

		RDM075	RDG075			RDM075	RDG075
A	in	3.05	3.05	K	in	∅ 0.5512 / 0.5508	∅ 0.6302 / 0.6298
	mm	77.4	77.4		mm	14 h6	16 j6
B	in	∅ 0.1969 / 0.1957	∅ 0.1969 / 0.1957	L	in	1.18	1.18
	mm	5 h9	5 h9		mm	30.0	30.0
C	in	□ 3.05	□ 3.05	M	in	See Below	See Below
	mm	77.4	77.4		mm	See Below	See Below
D	in	4X ∅ 0.26 ON BC	4X ∅ 0.26 ON BC	N	in	4.59	4.59
	mm	6.5	6.5		mm	116.6	116.6
E	in	∅ 3.74 BC	∅ 3.74 BC	O	in	1.5	1.5
	mm	95.0	95.0		mm	38.1	38.1
F	in	∅ 2.5587 / 2.5580	∅ 2.5587 / 2.5580	P	in	5.30	5.30
	mm	65 g6	65 g6		mm	134.5	134.5
G	in	0.63	0.70	Q	in	1.06	1.06
	mm	15.9	17.9		mm	27.0	27.0
H	in	0.38	0.45	R	in	4.61	4.61
	mm	9.5	11.5		mm	117.0	117.0
I	in	0.11	0.11	S	in	0.75	0.75
	mm	2.8	2.8		mm	19.1	19.1
J	in	0.79	0.79	T	in	0.75	0.75
	mm	20.0	20.0		mm	19.1	19.1

### RDM075

Without Brake Option			
DIM	1 Stack Stator	2 Stack Stator	3 Stack Stator
M	7.57 (192.3)	8.57 (217.7)	9.57 (243.1)

With Brake Option			
DIM	1 Stack Stator	2 Stack Stator	3 Stack Stator
M	8.85 (224.8)	9.85 (250.2)	10.85 (275.6)

### RDG075

Without Brake Option			
DIM	1 Stack Stator 1 Stage Gearhead	2 Stack Stator 1 Stage Gearhead	3 Stack Stator 1 Stage Gearhead
M	9.19 (233.4)	10.19 (258.8)	11.19 (284.2)

With Brake Option			
DIM	1 Stack Stator 1 Stage Gearhead	2 Stack Stator 1 Stage Gearhead	3 Stack Stator 1 Stage Gearhead
M	10.42 (264.7)	11.42 (290.1)	12.42 (315.5)

Pre-sale drawings and models are representative and are subject to change. Certified drawings and models are available for a fee. Consult your local Exlar representative for details.

## RDM/G090 Base Actuator

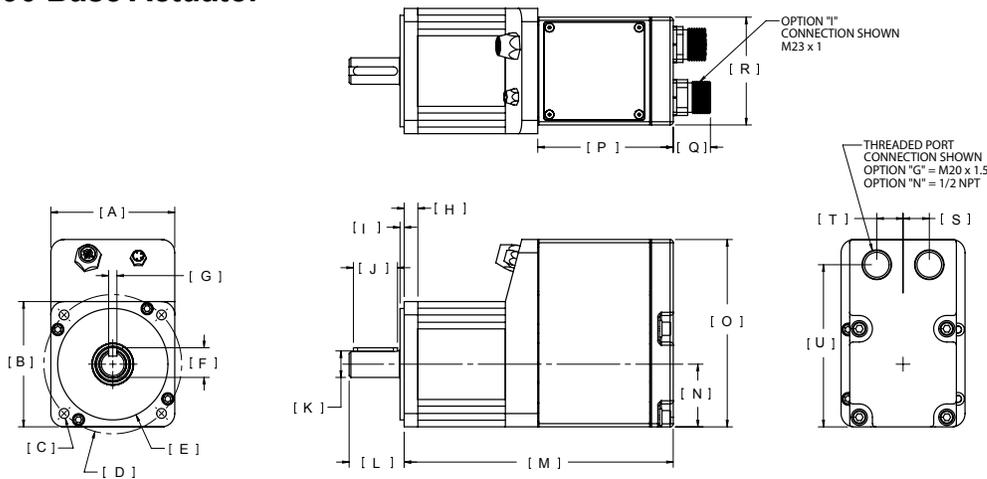

		RDM090	RDG090			RDM090	RDG090
<b>A</b>	in	3.54	3.54	<b>L</b>	in	1.57	1.89
	mm	90	90		mm	39.6	48.0
<b>B</b>	in	3.54	3.54	<b>M</b>	in	See Below	See Below
	mm	90	90		mm	See Below	See Below
<b>C</b>	in	4X Ø 0.28	4X Ø 0.26	<b>N</b>	in	1.77	1.77
	mm	7.0	6.5		mm	45.0	45.0
<b>D</b>	in	Ø 3.94 BC	Ø 3.94 BC	<b>O</b>	in	5.30	5.30
	mm	100.0	100.0		mm	134.5	134.5
<b>E</b>	in	Ø 3.1492 / 3.1485	Ø 3.1492 / 3.1485	<b>P</b>	in	3.87	3.87
	mm	80 g6	80 g6		mm	98.3	98.3
<b>F</b>	in	0.85	0.96	<b>Q</b>	in	1.06	1.06
	mm	21.5	24.3		mm	27.0	27.0
<b>G</b>	in	Ø 0.2362 / 0.2350	Ø 0.2362 / 0.2350	<b>R</b>	in	3.05	3.05
	mm	6 h9	6 h9		mm	77.4	77.4
<b>H</b>	in	0.39	0.63	<b>S</b>	in	0.75	0.75
	mm	10.0	15.9		mm	19.1	19.1
<b>I</b>	in	0.12	0.12	<b>T</b>	in	0.75	0.75
	mm	3.0	3.0		mm	19.1	19.1
<b>J</b>	in	1.26	1.42	<b>U</b>	in	4.58	4.58
	mm	32.0	36.0		mm	116.4	116.4
<b>K</b>	in	Ø 0.7480 / 0.7475	Ø 0.8665 / 0.8659				
	mm	19 h6	22 j6				

### RDM090

Without Brake Option			
DIM	1 Stack Stator	2 Stack Stator	3 Stack Stator
M	7.69 (195.3)	8.69 (220.7)	9.69 (246.1)

With Brake Option			
DIM	1 Stack Stator	2 Stack Stator	3 Stack Stator
M	9.0 (228.6)	10.00 (254.0)	11.00 (279.4)

### RDG090

Without Brake Option			
DIM	1 Stack Stator 1 Stage Gearhead	2 Stack Stator 1 Stage Gearhead	3 Stack Stator 1 Stage Gearhead
M	10.80 (274.3)	11.80 (299.7)	12.80 (325.1)
DIM	1 Stack Stator 2 Stage Gearhead	2 Stack Stator 2 Stage Gearhead	3 Stack Stator 2 Stage Gearhead
M	12.06 (306.3)	13.06 (331.7)	14.06 (357.1)

With Brake Option			
DIM	1 Stack Stator 1 Stage Gearhead	2 Stack Stator 1 Stage Gearhead	3 Stack Stator 1 Stage Gearhead
M	12.13 (308.1)	13.11 (333.0)	14.11 (358.4)
DIM	1 Stack Stator 2 Stage Gearhead	2 Stack Stator 2 Stage Gearhead	3 Stack Stator 2 Stage Gearhead
M	13.37 (339.6)	14.37 (365.0)	15.37 (390.4)

Pre-sale drawings and models are representative and are subject to change. Certified drawings and models are available for a fee. Consult your local Exlar representative for details.

## Ordering Information

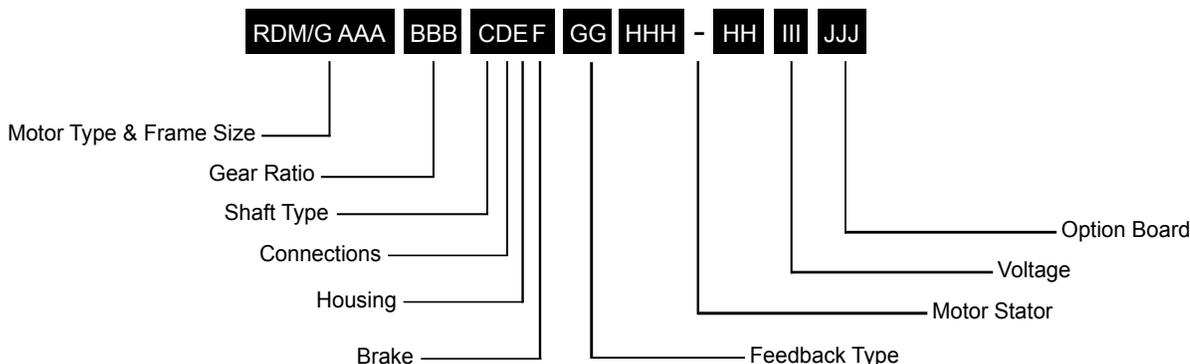

### RDM/G = Motor Type

RDM = Tritex II DC Rotary Motor  
RDG = Tritex II DC Rotary Gearmotor

### AAA = Frame Size

060 = 60 mm  
075 = 75 mm  
090 = 90 mm

### BBB = Gear Ratio

Blank = RDM  
Single Reduction Ratios  
004 = 4:1 005 = 5:1 010 = 10:1  
Double Reduction Ratios (NA on 75 mm)  
016 = 16:1 020 = 20:1  
025 = 25:1 040 = 40:1  
050 = 50:1 100 = 100:1

### C = Shaft Type

K = Keyed

### D = Connections

G = Standard straight threaded port with internal terminals, M20x1.5 (75 & 90 mm only)  
N = NPT threaded port internal terminals, 1/2" NPT (75 & 90 mm only)  
I = Intercontec style – Exlar standard, M23 Style Connector

### E = Housing Options

G = Exlar Standard

### F = Brake Options

S = No Brake, Standard  
B = Electric Brake, 24 VDC

### GG = Feedback Type

HD = Analog Hall Device  
IE = Incremental Encoder, 8192 Count Resolution  
AF = Absolute Feedback<sup>3</sup>

### HHH-HH = Motor Stators - All 8 Pole

RDM/G060 Stator Specifications  
1B8-50 = 1 Stack, 48 VDC, 5000 rpm  
2B8-50 = 2 Stack, 48 VDC, 5000 rpm  
3B8-40 = 3 Stack, 48 VDC, 4000 rpm

### RDM/G075 Stator Specifications

1B8-40 = 1 Stack, 48 VDC, 4000 rpm  
2B8-30 = 2 Stack, 48 VDC, 3000 rpm  
3B8-20 = 3 Stack, 48 VDC, 2000 rpm

### RDM/G090 Stator Specifications

1B8-33 = 1 Stack, 48 VDC, 3300 rpm  
2B8-18 = 2 Stack, 48 VDC, 1800 rpm  
3B8-14 = 3 Stack, 48 VDC, 1400 rpm

### III = Voltage

048 = 12-48 VDC

### JJJ = Option Board

SIO = Standard I/O Interconnect  
IA4 = + 4-20 mA Analog I/O  
EIP = SIO plus EtherNet/IP with M12 connector  
EIN = SIO plus EtherNet/IP without M12 connector<sup>2</sup>  
PIO = SIO plus Profinet IO w/M12 connector  
PIN = SIO plus Profinet IO without M12 connector<sup>2</sup>  
TCP = SIO plus Modbus TCP w/M12 connector  
TCN = SIO plus Modbus TCP without M12 connector<sup>2</sup>



For options or specials not listed above or for extended temperature operation, please contact Exlar

#### NOTES:

1. For extended temperature operation consult factory for model number.
2. Requires customer supplied Ethernet cable through I/O port for Class 1 Division 2 compliance only. Also N/A on 60 mm.
3. When ordering a TDM, RDM or RDG 60 mm or other sizes with top mounted connectors the battery backup for AF feedback must be mounted externally. A DIN rail mounted board (Exlar PN 48224) and battery (PN T2BAT2) are supplied.

## Cables and Accessories

<b>Tritex II DC Series Cable &amp; Accessories</b>	<b>Part No.</b>
<b>Communications Accessories - Tritex uses a 4 pin M8 RS485 communications connector</b>	
Recommended PC to Tritex communications cable-USB/RS485 to M8 connector - xxx = Length in feet, 006 or 015 only	CBL-T2USB485-M8-xxx
<b>Multi-Drop RS485 Accessories</b>	
RS485 splitter - M8 Pin plug to double M8 Socket receptacle	TT485SP
Multidrop Communications Cable M8 to M8 for use with TT485SP/RS485 splitter - xxx = Length in feet, 006 or 015 only	CBL-TTDAS-xxx
<b>“G” Connection Accessories (N/A for 60 mm)</b>	
Nickel plated cable gland- M20 x 1.5 - CE shielding- 2 required	GLD-T2M20 x 1.5
Power cable prepared on one end for use with GLD-T2M20 x 1.5 xxx = Length in ft, Standard lengths 015, 025, 050, 075, 100	CBL-TDIPC-RAW-xxx
I/O cable prepared on one end for use with GLD-T2M20 x 1.5 xxx = Length in ft, Standard lengths 015, 025, 050, 075, 100	CBL-T2IOC-RAW-xxx
<b>“N” Connection Accessories (N/A for 60 mm)</b>	
M20 x 1.5 to 1/2" NPT threaded hole adapter for use with conduit	ADAPT-M20-NPT1/2
<b>“I” Connection</b>	
Power cable with M23 8 pin xxx = Length in feet, std lengths 015, 025, 050, 075, 100	CBL-TTIPC-SMI-xxx
I/O cable with M23 19 pin xxx = Length in feet, std lengths 015, 025, 050, 075, 100	CBL-TTIOC-SMI-xxx
<b>Multi-Purpose Communications Accessories for long runs, requires terminal block interconnections</b>	
USB to RS485 convertor/cable - USB to RS485 flying leads - xxx = Length in feet, 006 or 015 only	CBL-T2USB485-xxx
Communications cable M8 to flying leads cable xxx = Length in feet, standard lengths 015, 025, 050, 075, 100	CBL-TTCOM-xxx
<b>Option Board Cables and Accessories</b>	
EIP, PIO and TCP option Ethernet cable - M12 to RJ45 cable xxx = Length in feet, standard lengths 015, 025, 050, 075, 100.	CBL-T2ETH-R45-xxx
<b>Electrical Accessories</b>	
Shunt resistor used for Dynamic Braking	TTSR1
Replacement -AF Battery - 75 mm frame only used for absolute feedback option	54108
Replacement -External Battery, Absolute Feedback option only (60mm frame)	T2BAT2
Replacement -AF Battery Board, T2BAT2 not included, DIN Rail mounted, Absolute Feedback option only (60mm frame)	48224
Surge Filter DIN rail mounted	TDCEFS1
Replacement Normally Closed External Limit Switch (Turck Part No. BIM-UNT-RP6X)	43404
Replacement Normally Open External Limit Switch (Turck Part No. BIM-UNT-AP6X)	43403



**CBL-T2USB485-M8-xxx**  
 Our recommended communications cable. No special drivers or setup required for use with MS Windows™.



**CBL-T2USB485-xxx**  
 Use for terminal connections with CBL-TTCOM for long cable runs. No special drivers or setup required for use with MS Windows™.



**CBL-TTIOC-SMI-xxx**



**CBL-TTIPC-SMI-xxx**



**CBL-TTCOM-xxx**  
 Use with CBL-T2USB485-xxx for long cable runs.

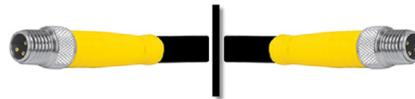

**CBL-TTDAS-xxx**  
 For use with TT485SP for multi-drop applications.



**TT485SP**  
 RS485 communications splitter. Use to daisy-chain multiple Tritex actuators.

#### TDCESF1

Surge filter designed for use on Tritex 48 VDC rotary and linear actuators provides EFT/B and surge disturbance immunity to IEC/EN 61800-3:2004-08 Second Environment (industrial) levels. Electrical Fast Transient/Burst (EET/B) and surge disturbances are caused by a number of events including switching inductive loads, relay contact bounce, power system switching activity or faults, nearby lightning strikes, etc.

## Warranty and Limitations of Liability

**WARRANTY AND LIMITATION OF LIABILITY:** Please see our warranty on our website here: <https://www.cw-actuation.com/en-gb/about/terms-conditions> for details.

### **USA & CANADA**

Exlar

18400 West 77th Street

Chanhassen, MN 55317

Phone: 855-620-6200 (US & Canada)

Fax: 952-368-4877

The logo for Exlar, featuring the word "EXLAR" in a bold, black, sans-serif font. The letter "X" is stylized with a diagonal slash through it. A registered trademark symbol (®) is located to the upper right of the "R".

**www.exlar.com**

*Exlar® actuators are a brand of Curtiss-Wright*